

Product Specifications

1-Gallon Round Container

Multiple Uses

Dry Products
Liquid Products

Product Codes

Container: **R015**
Description: 1-gallon round can

Features

Gauge: 50 mil.
Nominal capacity: 1 USG / 3.8L
Stack performance: 150 lbs.*
Tare weights: Body: .44 lbs. / .20 kgs.
Cover: .18 lbs. / .08 kgs.

Note: *Ratings will be reduced with uneven load distribution.

Specifications with Cover

Dimensions: 8-1/4"D X 7-7/16"H
Maximum capacity: 1.1 USG / 4.2L
Tare weight: .62 lbs. / .28 kgs.

Colors

Standard: White, Black and Natural
Custom: Available at manufacturer's discretion

Decorating Options

Silk - Screening: 20-3/4"W X 4-1/2"H
Four or six* color offset printing
Print area: 22-3/4"W X 4-1/2"H
Sleeve or pressure sensitive labeling
Note: *Where available

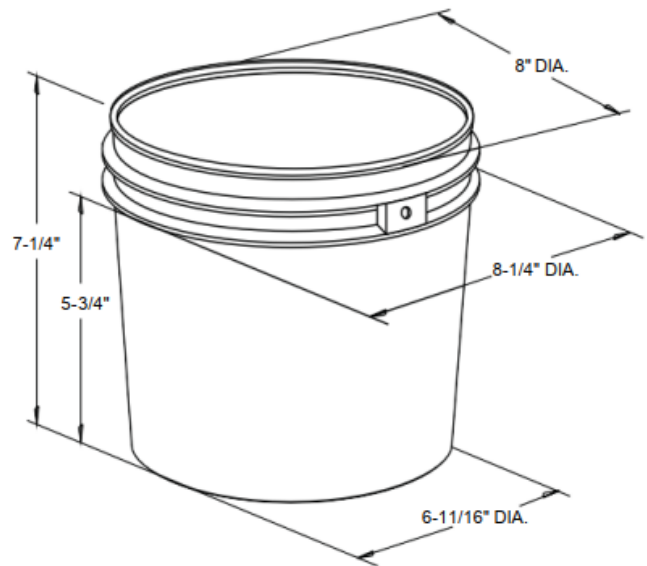

Shipping Data

Qty. per pallet:	450
Gross Weight (lbs./kgs.):*	198/90
Den. (lbs./C.F./Kgs./m3):	5.8/92.6
Length (in./cm.):	49.5/125.7
Width (in./cm.):	41.3/104.9
Height (in./cm.):	29/73.7

Estimated truckload quantity of 18,900 bodies and covers**

Bodies

Filled Containers

180 (30 per layer / 6 layers high)
Pallet height: 48"

Notes: *Weight does not include pallet/packaging
**Truckload quantity based on 53' trailer

Materials

FDA approved materials
Resin: Body: High-Density Polyethylene (HDPE)

Optional Carrying Handle

DISCLAIMER
THIS INFORMATION IS PROVIDED AS A GENERAL GUIDE, INCLUDING DIMENSIONS. IT IS THE CUSTOMER'S RESPONSIBILITIES TO SELECT THE PROPER CONTAINER FOR PRODUCT AND APPLICATION COMPATIBILITY.

DISTRIBUTED BY:



REF NO.:

DWG31414

DESCRIPTION:

1 Gallon HDPE Plastic Open Head Pail, w/ Metal Bail, White Plastic Grip