

715 5.5 Litre Pail

COMPONENTS

- Material: Food approved high density polyethylene
- Standard Color: White (Other colors on request)
- Plastic Handle
- Gasket: EPDM (Ethylene Propylene Diene Monomer)

WALL THICKNESS	cm	inch
• Pail	.145	.057
• Gasket Tear Tab Lid (621)	.135	.053
• Snap On Tear Tab Lid (622)	.142	.056

STANDARD WEIGHT (+/- 2%)	g	lb.
• Pail (including handle)	267	0.59
• Gasket Lid (including gasket) (621)	87	0.19
• Snap On Tear Tab Lid (622)	71	0.16

THERMAL RESISTANCE (Tested with water)

- Filling from -38°C (-36°F) to 82°C (180°F)
- Warehousing from -40°C (-40°F) to 39°C (102°F)

TOP LOADING RESISTANCE	kg	lb.
• With Gasket Lid (621)	100	220
• With Snap-On Lid (622)	100	220

CAPACITIES

VOLUME	Litres	GALLONS	
		Imp.	U.S.
Nominal	5.50	1.21	1.45
Maximum to Overflow	6.17	1.36	1.63
Maximum with Gasket Lid	5.77	1.27	1.52
Maximum with Snap-On Lid	5.87	1.29	1.55

PRODUCT DENSITY g/cm ³	Maximum Weight Filled with Lid			
	GASKET LID		SNAP-ON LID	
	kg	lb	kg	lb
0.5	3.06	6.73	3.10	6.82
0.6	3.67	8.08	3.72	8.19
0.7	4.28	9.42	4.34	9.55
0.8	4.90	10.77	4.96	10.92
0.9	5.51	12.12	5.58	12.28
1.0	6.12	13.46	6.20	13.65
1.1	6.73	14.81	6.82	15.01
1.2	7.34	16.15	7.44	16.38
1.3	7.95	17.50	8.06	17.74
1.4	8.57	18.85	8.68	19.11
1.5	9.18	20.19	9.30	20.47

Above is a guideline only.

Customer should verify with specific product to be packaged.

622 SNAP ON LID

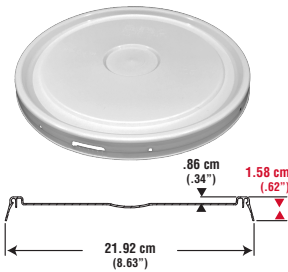

621 GASKET LID

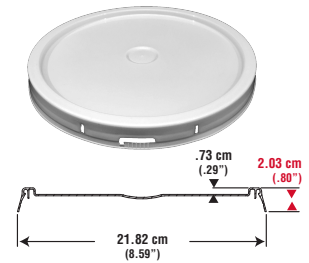

5.5 LITRE PAIL

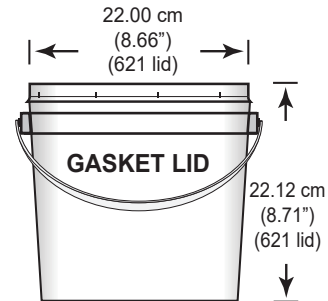
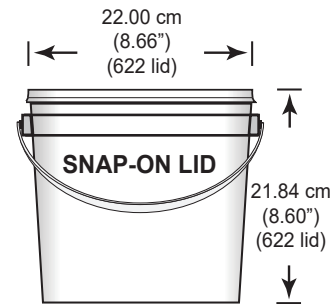

NESTING

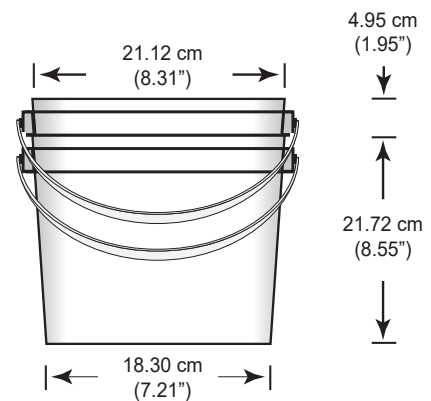

DISTRIBUTED BY:



REF NO.:

DWG31417

DESCRIPTION:

1.5 Gallon HDPE Cover with EPDM Gasket

DISCLAIMER

THIS INFORMATION IS PROVIDED AS A GENERAL GUIDE, INCLUDING DIMENSIONS. IT IS THE CUSTOMER'S RESPONSIBILITIES TO SELECT THE PROPER CONTAINER FOR PRODUCT AND APPLICATION COMPATIBILITY.