

<p align="center">DISCLAIMER</p> <p>THIS INFORMATION IS PROVIDED AS A GENERAL GUIDE, INCLUDING DIMENSIONS. IT IS THE CUSTOMER'S RESPONSIBILITIES TO SELECT THE PROPER CONTAINER FOR PRODUCT AND APPLICATION COMPATIBILITY.</p>	<p>DISTRIBUTED BY: </p>	<p>REF NO.:</p> <p align="center">DWG 31229</p>
	<p>DESCRIPTION:</p> <p align="center">1 Gallon Black Steel Open Head Steel Pail, Red Brown Phenolic Lining, w/ Cover</p>	

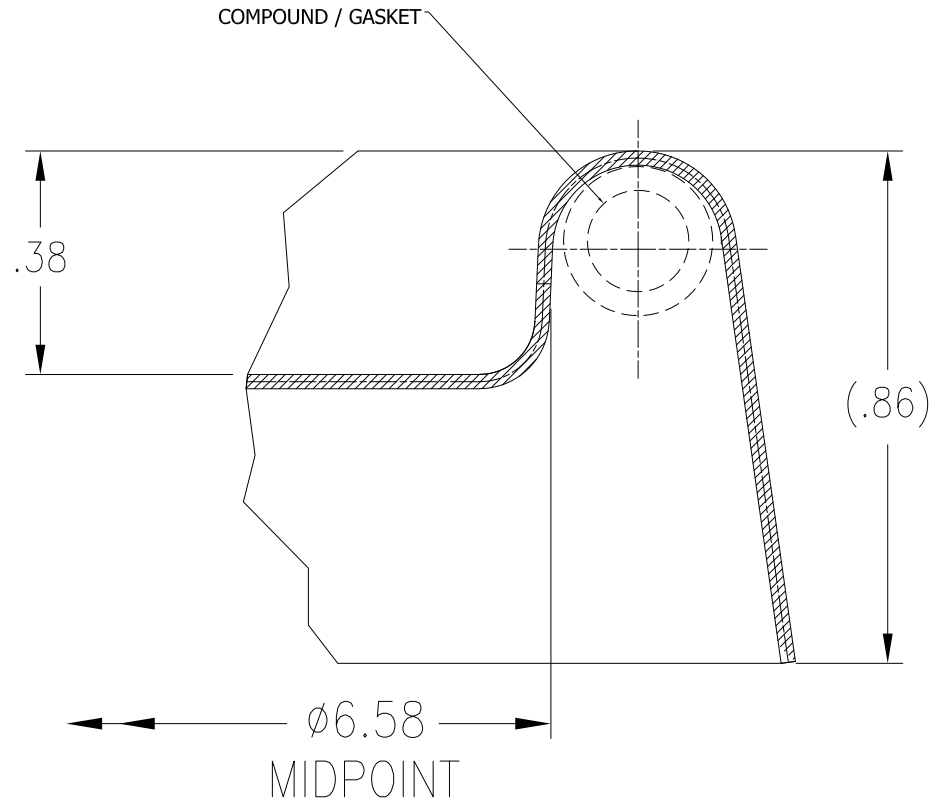
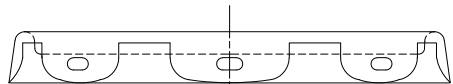
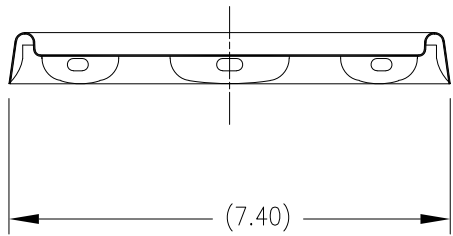
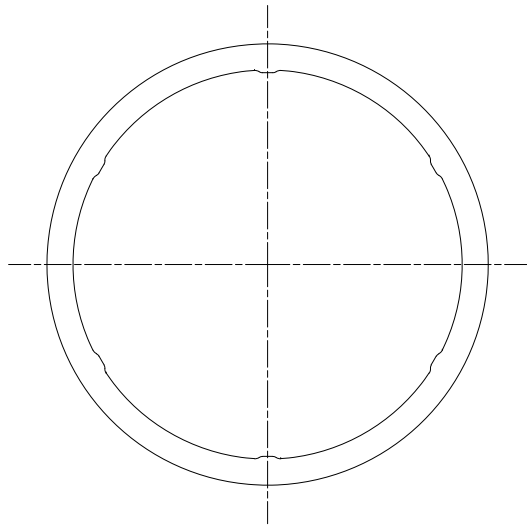

DISCLAIMER

THIS INFORMATION IS PROVIDED AS A GENERAL GUIDE, INCLUDING DIMENSIONS. IT IS THE CUSTOMER'S RESPONSIBILITIES TO SELECT THE PROPER CONTAINER FOR PRODUCT AND APPLICATION COMPATIBILITY.

DISTRIBUTED BY:



REF NO.:

DWG 31229

DESCRIPTION:

1 Gallon Black Steel Open Head Steel Pail, Red Brown Phenolic Lining, w/ Cover