

TYPE :	CONICAL PAIL LT 23 Ø 286X367	
TYPE OF CLOSURE	<b>TOTAL OPENING LID + ZINC RING + CAP</b>	
TOTAL CAPACITY	LITRES	- LT. 22.5
DIMENSION	UPPER DIAMETER	- INTERNAL 286 MM. +/- 1MM
	LOWER DIAMETER	- INTERNAL 270 MM. +/- 1 MM
THICKNESS	HEIGHT	- EXTERNAL 367 MM. +/- 2 MM.
	BEAD SPACING	- 1
TOLERANCE	BODY	- 0,34 MM.
	BOTTOM	- 0,34 MM.
	LID	- 0,34 MM.
QUALITY STEEL	TIN PLATE	- EN 10202
TARA - WEIGHT	TIN	- BES
	COMPLETED	- 2,8 - 2,8 GR/M <sup>2</sup>
CLOSURE	TOTAL	- KG. 1,65 +/- 4%
	OPENING LID	- Ø 286 MM WITH GASKET COV 53 GRACE
HANDLE	ZINC RING	- 22X1.0 MM HANDLE T38
	HANDLE ARC	- ZINC WIRE Ø 3.8 MM + HANDLE IN POLYETHYLENE
CONSTRUCTION	CLUTCHING	- TRIPLE WITH GASKET GRACE OP699
	BEAD	- 60 MM
LACQUERING	INTERNAL	- PLAIN
	WELDING POINT	- NO
LITHOGRAPHED	INTERNAL LID	- PLAIN
	INTERNAL BOTTOM	- PLAIN
	EXTERNAL BODY	- ENAMEL WHITE
	EXTERNAL LID	- PLAIN
TEST	EXTERNAL BOTTOM	- ENAMEL WHITE
	SEAL TEST	- 100% TESTED WITH TESTER MACHINE
<b>UN HOMOLOGATION</b>		- ONU 1A2/Y1.3/110/YEAR F /SLF / LRM T095
		- ONU 1A2/Y 50/S/**/F/SLF/LRM T094
MARK	BODY	- LITHOGRAPHED
	LID AND RING	- IMPRESSED
	WOOD PALLET	- EURO PALLETS 115X115 PIECES 364

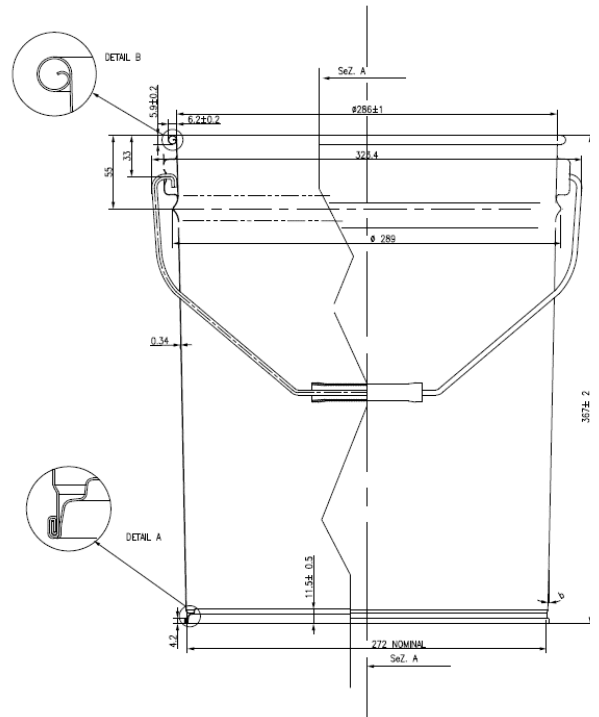

DISTRIBUTED BY:



REF NO.:

DWG31268

DESCRIPTION:

20 Liter White Tin Plate Open Head Pail, Unlined

DISCLAIMER

THIS INFORMATION IS PROVIDED AS A GENERAL GUIDE, INCLUDING DIMENSIONS. IT IS THE CUSTOMER'S RESPONSIBILITIES TO SELECT THE PROPER CONTAINER FOR PRODUCT AND APPLICATION COMPATIBILITY.