

NOTES:

- 1) CAPS ARE PRODUCED ACCORDING TO CMA STANDARDS AND ARE SUITABLE FOR GLASS FINISH GPI 38-400
- 2) DIMENSION OF THREAD INTERNAL DIAMETER TAKEN WITH A PLUG GAGE
- 3) MIN. PLASTISOL THICKNESS 0.025" IF APPLICABLE

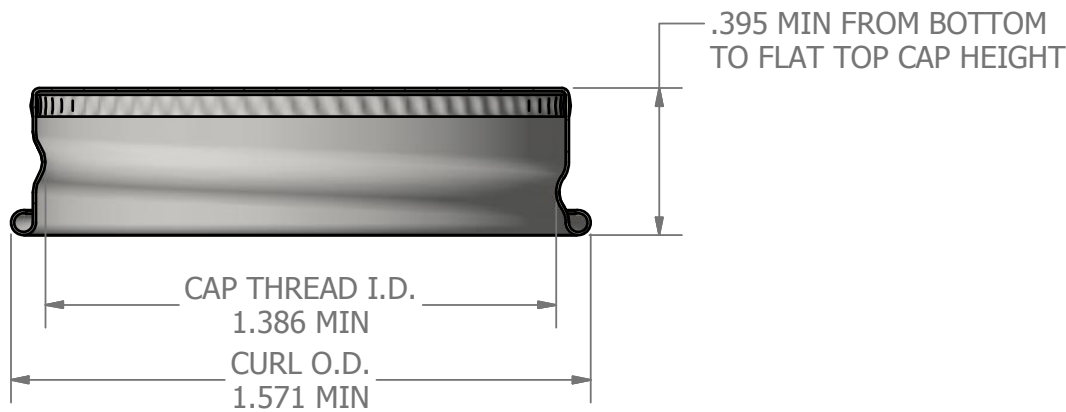

SECTION A-A  
SCALE 2 : 1

**DISCLAIMER**

THIS INFORMATION IS PROVIDED AS A GENERAL GUIDE, INCLUDING DIMENSIONS. IT IS THE CUSTOMER'S RESPONSIBILITIES TO SELECT THE PROPER CONTAINER FOR PRODUCT AND APPLICATION COMPATIBILITY.

DISTRIBUTED BY:



REF NO.:

DWG31459

DESCRIPTION:

28-400 Black Metal Screw Cap with Pulp & Vinyl Liner

# Technical Data

## Pharm-Seal® V Vinyl Liner

Pharm-Seal® V is a primary liner that has clear, gloss, cross-linked polyvinyl coating as the product contact surface. This product is designed to meet the specific demands of pharmaceutical packaging. This liner provides reseal and good barrier to oxygen and moisture. Pharm-Seal® V is compatible with a wide range of products. This primary liner is most typically backed with pulp, but is also available with paper or polystyrene backing. Pharm-Seal® V is available plain or waxed.

### Structure

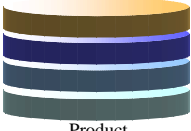
Material		Thickness* (Mils)	Thickness* (Microns)
Pulp		As specified	As specified
Bleach Kraft		2.5	63.5
High-Density Polyethylene		1.0	25.4
Polyvinyl Coating		0.35	8.9
Total (add specified pulp thickness)		3.9**	97.8**

\* The information listed reflects target values, and there will be variation in these values within acceptable industry standards ( $\pm 10\%$ ).

\*\* Note: The thickness of the total structure may not necessarily be the sum of the individual layers, and the total thickness reported is based upon actual measurements.

### FDA Status

All components and the manufacture of this seal comply with the U.S. Federal Government's Code of Federal Regulations 21CFR177.1210, Closures with sealing gaskets for food containers. Information pertaining to Tech-Seal Products, Inc. and its products are entered into Drug Master File 14762.

### Physical Properties

**Appearance:**    Non-Product Side                      Product Side  
                                  Matte Manila    Gloss White

**Pinholes** (Qty/YD<sup>2</sup>): < 6

**Oxygen Transmission Rate** (cc / 100 in<sup>2</sup> / 24 hr @ 75° F & 5 0% R. H.): < 10.0

**Moisture Vapor Transmission Rate** (g / 100 in<sup>2</sup> / 24 hr @ 100° F, 90% R.H.): < 0.5

### Suggested Product Applications

Alcohol, ammonia, antacids, auto cleaners, bleaching agents, castor oil, cod liver oil, cosmetics cottonseed oil, detergents, distilled beverages, food extracts, hair care products, lemon juice, lime juice, mineral oil, personal care products, pharmaceuticals, mineral oil, vegetable oil, wax, wine and witch hazel.

The products listed above are a partial listing of suitable applications for this product. This listing is provided as a reference for how this product may be used. However, the user is responsible for testing the suitability of this product for a specific application.

<b>DISCLAIMER</b>  THIS INFORMATION IS PROVIDED AS A GENERAL GUIDE, INCLUDING DIMENSIONS. IT IS THE CUSTOMER'S RESPONSIBILITIES TO SELECT THE PROPER CONTAINER FOR PRODUCT AND APPLICATION COMPATIBILITY.	DISTRIBUTED BY:  Pipeline Packaging	REF NO.: DWG31459
	DESCRIPTION: 28-400 Black Metal Screw Cap with Pulp & Vinyl Liner	