

HIGH DENSITY POLYETHYLENE RING/FS-60-B

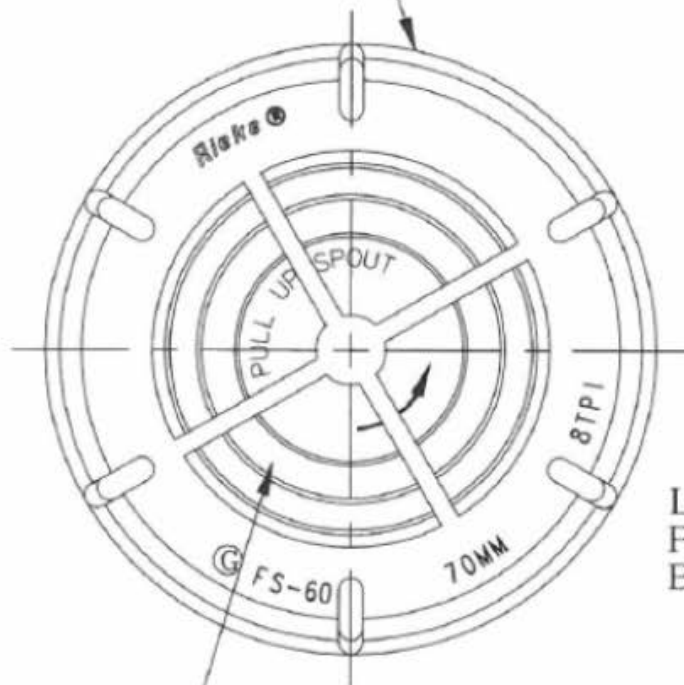

HIGH DENSITY POLYETHYLENE CAP/FS-10-B-5

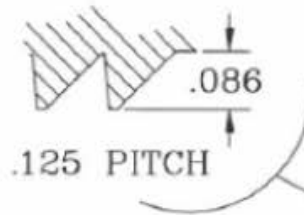

THREAD SPECS	
S	.03 MINIMUM
T	ø2.767 MINIMUM
E	ø2.650 / ø2.613
TPI	8 THDS. PER INCH

EPDM SEALING GASKET

LOW DENSITY POLYETHYLENE BODY/FS-60-A-1

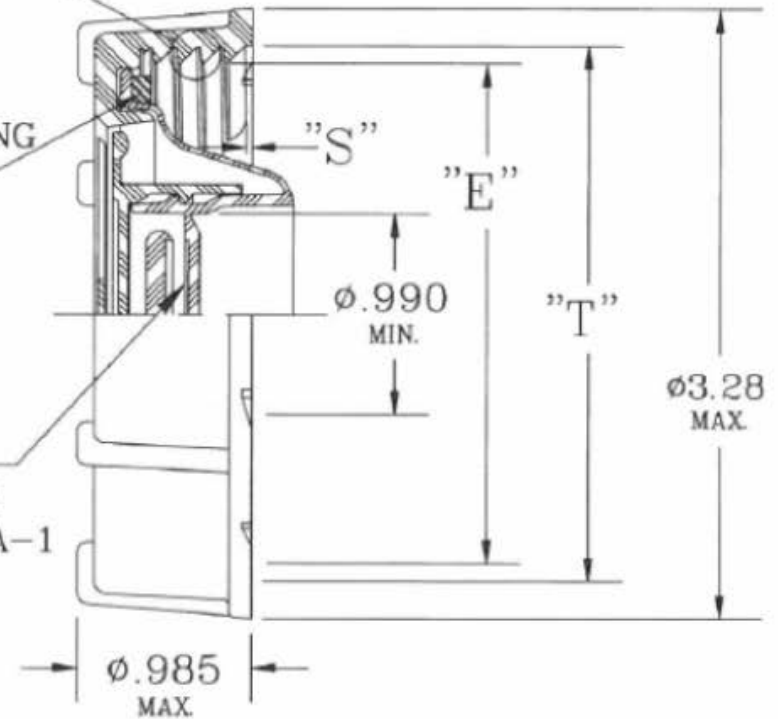

NOTE: MATERIALS USED MEET FDA REQUIREMENTS

DISCLAIMER

THIS INFORMATION IS PROVIDED AS A GENERAL GUIDE, INCLUDING DIMENSIONS. IT IS THE CUSTOMER'S RESPONSIBILITIES TO SELECT THE PROPER CONTAINER FOR PRODUCT AND APPLICATION COMPATIBILITY.

DISTRIBUTED BY:



REF NO.:

DESCRIPTION: