

NOTE: THE CAP IS SHOWN WITHOUT A LINER

©

LINER #	LINER DESCRIPTION
502	F217 FOAM
565	1 MIL HEAT SEAL
655	PS113 PRESSURE SENSITIVE W/FOAM BACKING

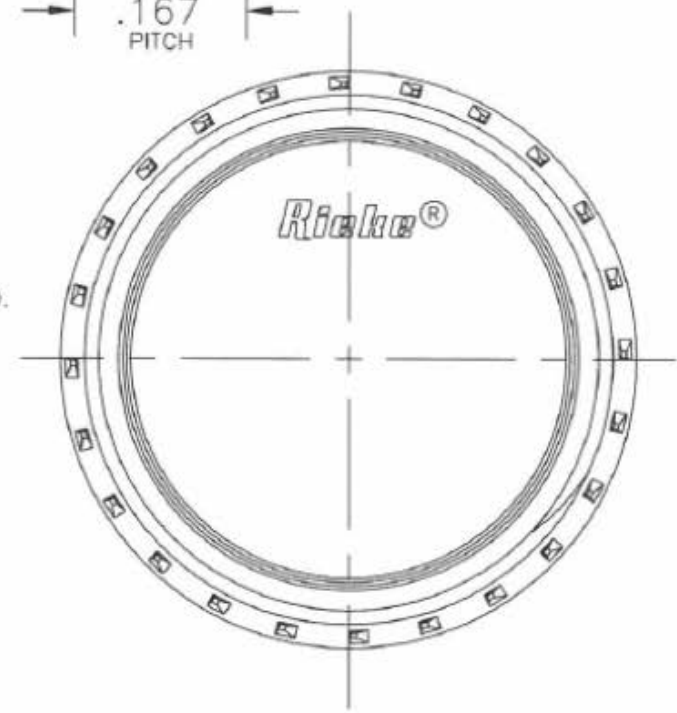
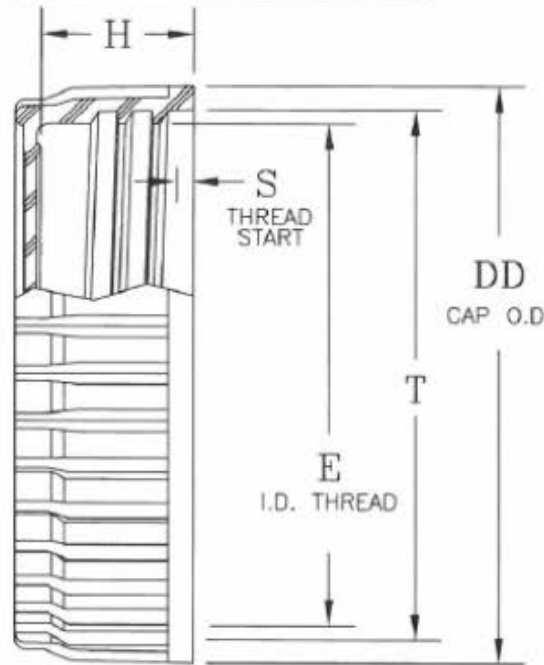
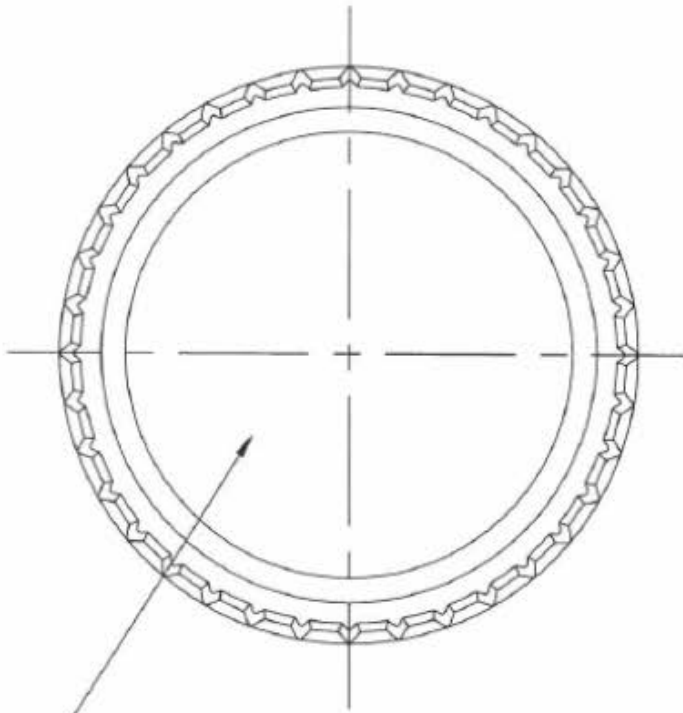
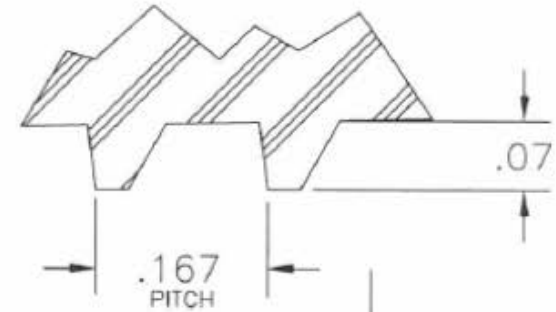

ⓑ OPTION: PRINTING OR EMBOSsing TO CUSTOMER REQUIREMENTS

ITEM	DD	E	H	S	T
SPEC.	$\phi 2.757 \pm .012$	$\phi 2.389 \pm .011$	$.725 \pm .008$	$.070 \pm .015$	$\phi 2.541 \pm .013$

NOTE:

THE MATERIALS USED MEETS FDA REQUIREMENTS DEPENDING ON COLOR

**DISCLAIMER**

THIS INFORMATION IS PROVIDED AS A GENERAL GUIDE, INCLUDING DIMENSIONS. IT IS THE CUSTOMER'S RESPONSIBILITIES TO SELECT THE PROPER CONTAINER FOR PRODUCT AND APPLICATION COMPATIBILITY.

DISTRIBUTED BY:



REF NO.:

DWG20565

DESCRIPTION:

63 mm PP Screw Cap