

WEIGHT 150 Grams (+/- 5 g.) COLOR Natural

BOTTLE DIMENSIONS			
NECK I.D.	1.100 min.	NECK FINISH	Rexam 38mm CR SnapLok
HEIGHT OVER HANDLE	11.800 +/- .080	HEIGHT OVER NECK	11.700 +/- .080
DEPTH	4.100 +/- .080	WIDTH	7.450 +/- .090
"E" DIMENSION	1.358 - 1.382	"T" DIMENSION	1.452 - 1.476
"S" DIMENSION	.055 - .085	"H" DIMENSION	.635 - .665
WALL THICKNESS	.015 min.	BEAD DIAMETER	1.518 - 1.552
		RATCHET DIAMETER	N/A

38mm-REXAM CR SNAPLOK

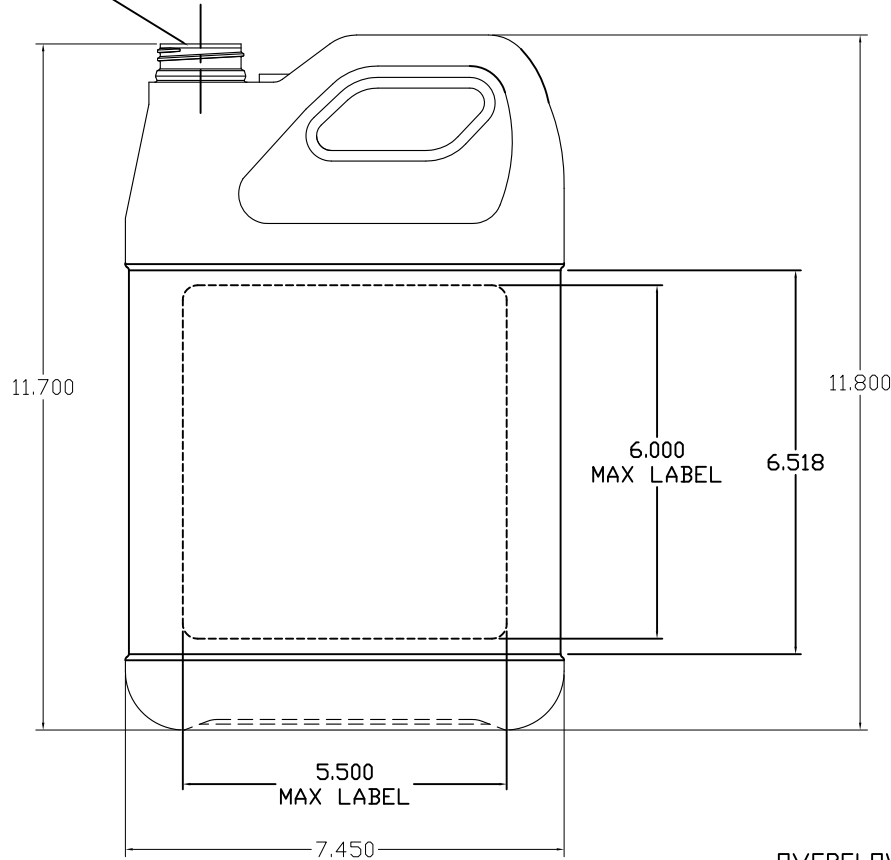
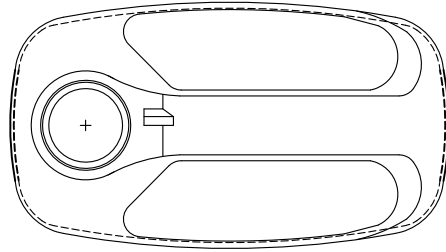

OVERFLOW CAPACITY = 144 FL/OZ

**DISCLAIMER**

THIS INFORMATION IS PROVIDED AS A GENERAL GUIDE, INCLUDING DIMENSIONS. IT IS THE CUSTOMER'S RESPONSIBILITIES TO SELECT THE PROPER CONTAINER FOR PRODUCT AND APPLICATION COMPATIBILITY.

DISTRIBUTED BY:



REF NO.:

DWG31149

DESCRIPTION:

128 oz Natural HDPE F-Style, 38-400 Rexam with Graduations, 150 Gram