

18 mm Closed Vent Cap

10 1/4

NOTES:

1. MATERIAL: PREMIUN HDPE
2. STANDARD COLORS: NATURAL, WHITE, BLUE
3. CERTIFIED TO UN Y1.8/100
4. TARE WEIGHT: 1275 GRAMS
5. RATED CAPACITY: 20 LITERS
OVERFLOW CAPACITY: 21.2 LITERS (6% OVERAGE)

AVAILABLE WITH VARIOUS NECK FINISHES.
(SHOWN WITH 2" INTERNAL BUTTRESS)

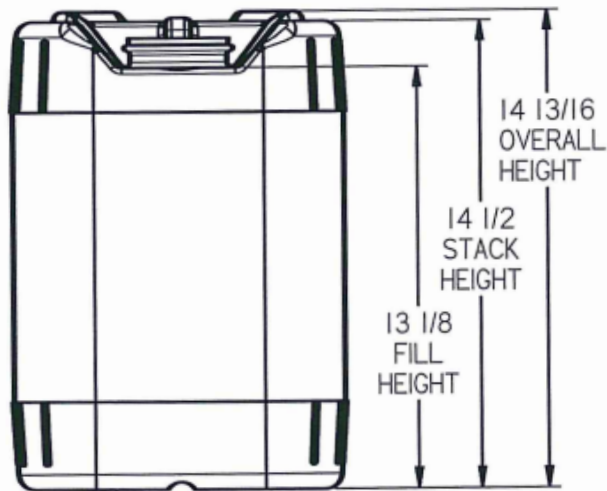

14 13/16
OVERALL
HEIGHT

14 1/2
STACK
HEIGHT

13 1/8
FILL
HEIGHT

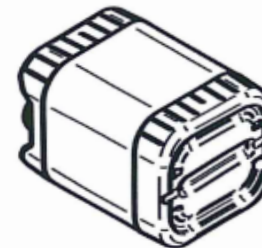
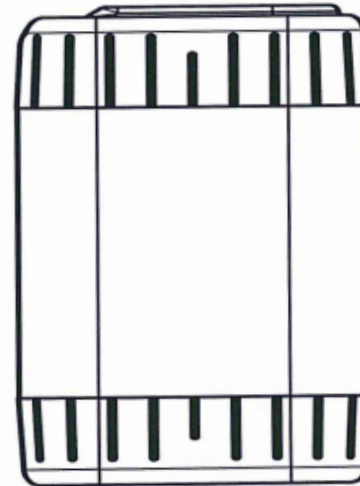

DISCLAIMER

THIS INFORMATION IS PROVIDED AS A GENERAL GUIDE, INCLUDING DIMENSIONS. IT IS THE CUSTOMER'S RESPONSIBILITIES TO SELECT THE PROPER CONTAINER FOR PRODUCT AND APPLICATION COMPATIBILITY.

DISTRIBUTED BY:



REF NO.:

DWG 31232

DESCRIPTION:

20 Liter Natural HDPE Plastic Square TH Pail, 70 mm, Tamper Evident, 6TPI, Integrated Handles