

1-Gallon Round High Performance Container with Gasket Cover

Multiple Uses

Dry Products
Liquid Products

Product Codes

Container: **R16**
Description: 1-gallon round high performance container

Cover: **T1EG**

Description: Tamper-evident, round cover with tubular gasket

Features

Gauge: 65 mil.
Nominal capacity: 1 USG / 3.8 L
Stack performance: 200 lbs.*
Tare weights: Body: .485 lbs. / .22 kgs.
Cover: .22 lbs. / .10 kgs.
*Note: *Ratings will be reduced with uneven load distribution.*

Specifications with Cover

Dimensions: 8-1/4"D X 7-3/8"H
Maximum capacity: 1.1 USG / 4.2 L
Tare weight: .705 lbs. / .32 kgs.

Colors

Standard: White, Black and Natural
Custom: Available at manufacturer's discretion

Decorating Options

Four or six* color offset printing
Print area: 22-3/4"W X 4-1/2"H
Sleeve or pressure sensitive labeling
*Note: *Where available*

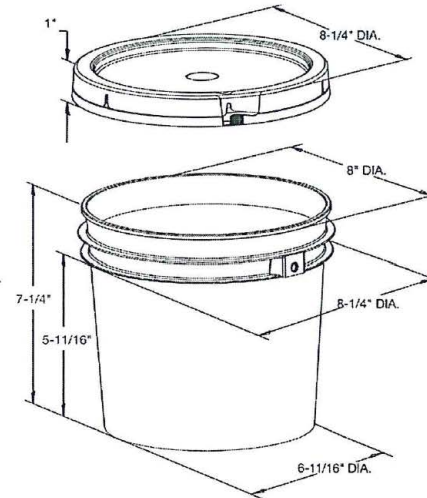

Shipping Data

Qty. per pallet: 900
Gross Weight (lbs./kgs.): 436.5/198
Length (in./cm.): 51.25/130.2
Width (in./cm.): 43/109.2
Height (in./cm.): 68.25/173.4
Estimated truckload quantity of 21,000 bodies and covers**

Bodies

Covers

Filled Containers

180 (30 per layer/6 layers high)
Pallet height: 48"

*Notes: *Weight does not include pallet/packaging
**Truckload quantity based on 53' trailer*

Materials

FDA approved materials
Resin: Body: High-Density Polyethylene (HDPE)
Cover: High-Density Polyethylene (HDPE)
Styrene Butadiene Rubber (SBR) Gasket
MSDS Sheets available upon request

Optional Carrying Handle

<p>DISCLAIMER</p> <p>THIS INFORMATION IS PROVIDED AS A GENERAL GUIDE, INCLUDING DIMENSIONS. IT IS THE CUSTOMER'S RESPONSIBILITIES TO SELECT THE PROPER CONTAINER FOR PRODUCT AND APPLICATION COMPATIBILITY.</p>	<p>DISTRIBUTED BY:</p> <p>DESCRIPTION: 1 gallon HDPE Open Head Pail</p>	<p>REF NO.: DWG20638</p>
--	---	------------------------------