

## 6.0 Gallon LBR Pail with Tear Skirt Cover

\*Note: Available with UN-Solids Y27/S rating

### Multiple Uses

Dry Products

Liquid Products

### Product Codes

Pail: **5600 Series**

Description: 6.0 Gallon LBR Standard Pail

Cover: **6500 Series**

Description: Standard Tear Skirt Cover

Note: \*Multiple fitting and venting options available

### Features

Gauge: 90 mil

Nominal capacity: 6.0 USG / 22.7 L

Stack performance: 350 lbs.\*

Tare weights: Body: 2.36 lbs. / 1,075 gr.

Cover: .66 lbs. / 300 gr.

Note: \*Ratings will be reduced with uneven load distribution.

### Specifications with Cover

Dimensions: 12 3/8"D. X 17 9/16"H

Maximum capacity: 6.36 USG / 24 L

Tare weight: 3.02 lbs. / 1.37 kgs.

### Colors

Standard: White, Black and Natural

Custom: Available at manufacturer's discretion

### Decorating Options

Four color offset printing

Print area: 33"W X 10-1/4"H

Sleeve or pressure sensitive labeling

### Shipping Data

Qty. per pallet/carton:

### Bodies

192\*

Gross Weight (lbs/kgs.)\*\*:

453/205.5

Length (in./cm.):

50/127

Width (in./cm.):

38.5/97.8

Height (in./cm.):

102/259

Approximate truckload quantity of 4,416 pails and covers\*\*\*

### Covers

1,200\*

792/359

48/121.9

40/101.6

98/249

### Filled Containers

36 (12 per layer/3 layers high)

Pallet height: 53"

Notes:

\*Quantity can vary based on customer request

\*\*Weight does not include pallet/packaging

\*\*\*Approximate truckload quantity of 4,416 pails and covers

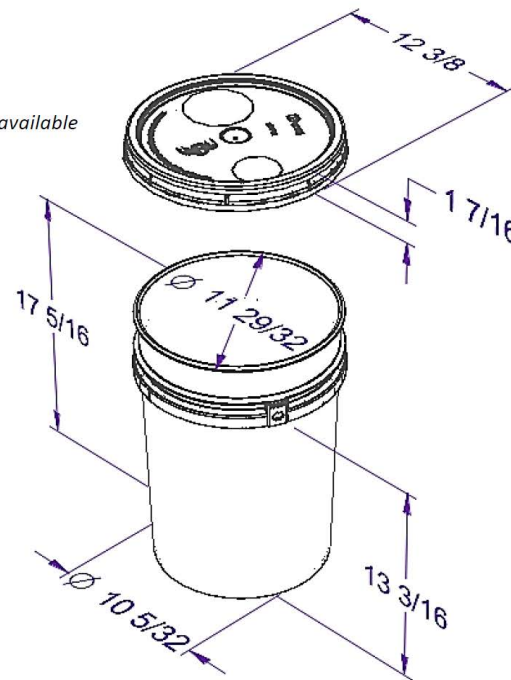

## Materials

FDA approved materials

Resin: Body: High-Density Polyethylene (HDPE) Cover: High-Density Polyethylene (HDPE)

MSDS Sheets available upon request

## Optional Carrying Handle – Wire or Plastic

### DISCLAIMER

THIS INFORMATION IS PROVIDED AS A GENERAL GUIDE, INCLUDING DIMENSIONS. IT IS THE CUSTOMER'S RESPONSIBILITIES TO SELECT THE PROPER CONTAINER FOR PRODUCT AND APPLICATION COMPATIBILITY.

DISTRIBUTED BY:



REF NO.:

DESCRIPTION: