

3.5-Gallon Round Container with Lo-Vis EZ Cover®

Multiple Uses

Dry Products
Liquid Products

Product Codes

Container: **R039**
Description: 3.5-gallon round can

Cover: **LTGZ**

Description: Tamper-evident, Lo-Vis EZ Cover® with four tabs and tubular gasket

Features

Gauge: 90 mil.
Nominal capacity: 3.5 USG / 13.2 L
Stack performance: 400 lbs. *
Tare weights: Body: 1.61 lbs. / .73 kgs.
Cover: .58 lbs. / .26 kgs.

Note: *Ratings will be reduced with uneven load distribution.

Specifications with Cover

Dimensions: 12-3/8"D X 11-1/2"H
Maximum capacity: 4.1 USG / 15.5 kgs.
Tare weight: 2.19 lbs. / .99 kgs.

Colors

Standard: White, Black and Natural
Custom: Available at manufacturer's discretion

Decorating Options

Silk-Screening: 32-1/4"W X 7"H
Four or six* color offset printing
Print area: 34-1/4"W X 7"H

Note: *Where available

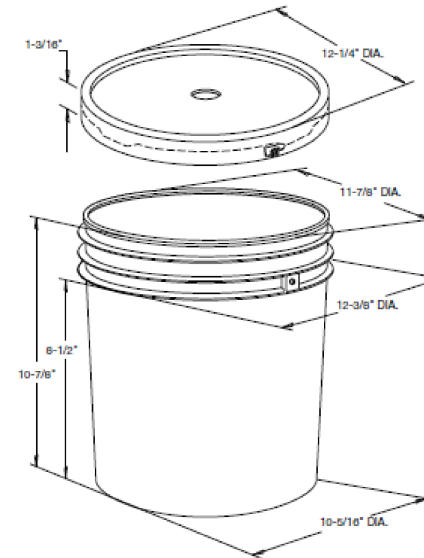

Shipping Data

Qty. per pallet/carton: 144
Gross Weight (lbs./kgs)**: 231.8/105.1
Den. (lbs./C.F./kgs./m3): 6.3/100.6
Length (in./cm.): 49.3/125.2
Width (in./cm.): 37.5/95.3
Height (in./cm.): 34.5/87.6
Estimated truckload quantity of 8,640 bodies and covers***

Bodies

Covers

Filled Containers

1,152 (24 boxes of 48)*
48 (12 per layer / 4 layers high)
Pallet height: 48"

Notes: *Bulk pack also available
**Weight does not include pallet/packaging
***Truckload quantity based on 53' trailer

Materials

FDA approved materials
Resin: Body: High-Density Polyethylene (HDPE)
Cover: High-Density Polyethylene (HDPE)
Styrene Butadiene Rubber (SBR) Gasket
MSDS Sheets available upon request

Optional Carrying Handle

DISCLAIMER

THIS INFORMATION IS PROVIDED AS A GENERAL GUIDE, INCLUDING DIMENSIONS. IT IS THE CUSTOMER'S RESPONSIBILITIES TO SELECT THE PROPER CONTAINER FOR PRODUCT AND APPLICATION COMPATIBILITY.

DISTRIBUTED BY:



DWG NO.:

DWG10144

DESCRIPTION:

3.5 gallon HDPE Open Head Pail