

8-13 Gallon EZ STOR® Hinged Cover

Multiple Uses

Dry Products

Cover: **E8DH**

Description: Dry seal, tamper-evident, hinged, EZ open & close cover

Features

- Built in hand grips
- Gauge: 90 mil.
- Nominal capacity: 13 USG / 49.2 L
- Stack performance: 200 lbs.*
- Tare weights: Body: 4.06 lbs. / 1.84 kgs.
Cover: .66 lbs. / .3 kgs.

Note: *Ratings will be reduced with uneven load distribution.

Specifications with Cover

- Dimensions: 16-5/16"L X 13-1/2"W X 18-11/16"H
- Maximum capacity: 13.4 USG / 50.7 L
- Tare weight: 4.72 lbs. / 2.14 kgs.

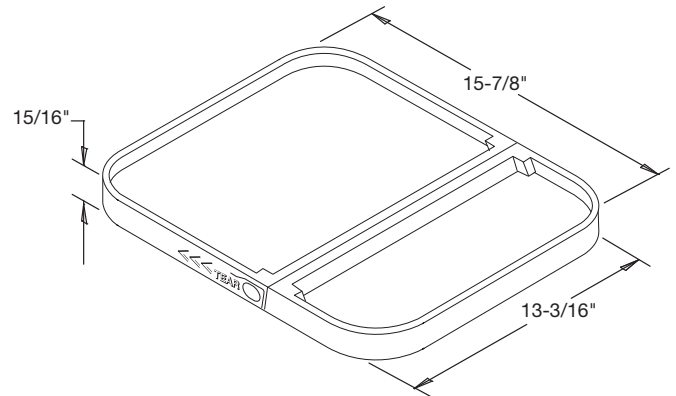

Colors

- Standard: White, Black and Natural
- Custom: Available at manufacturer's discretion

Decorating Options*

- Silk-Screen**
- Pressure sensitive labels: 8"W X 7"H
- Logo emboss for cover: 7-3/4"W X 4"H

Note: *See EZ Stor Decoration Summary for further details.

**Where available.

Shipping Data

- Qty. per pallet:
- Weight (lbs./kgs.)**:
- Den. (lbs./C.F./kgs./m3):
- Length (in./cm.):
- Width (in./cm.):
- Height (in./cm.):

Covers

- 1,215 (45 boxes of 27)*
- 801.9/364.5
- 7.2/115.7
- 51.0/129.5
- 42.0/106.7
- 90.0/228.6

Materials

- FDA approved materials
- Resin: Body: High Density Polyethylene (HDPE)
Cover: Polypropylene (PP)
- MSDS Sheets available upon request

DISTRIBUTED BY:



REF NO.:

DWG31285

DESCRIPTION:

8-13 Gallon White HDPE Plastic EZ Stor Cover

DISCLAIMER

THIS INFORMATION IS PROVIDED AS A GENERAL GUIDE, INCLUDING DIMENSIONS. IT IS THE CUSTOMER'S RESPONSIBILITIES TO SELECT THE PROPER CONTAINER FOR PRODUCT AND APPLICATION COMPATIBILITY.