

SECTION A-A

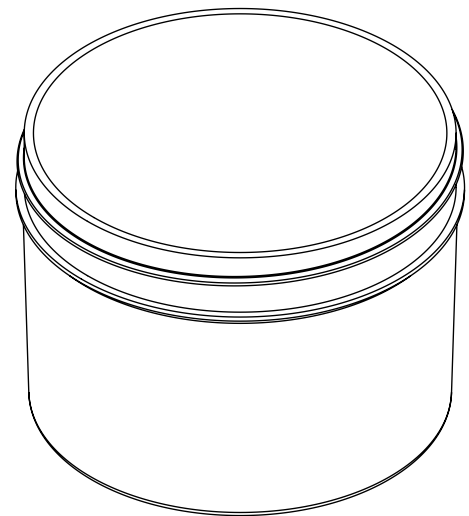

REFERENCE	DIMENSION	TOLERANCE	UNITS
Ø T	3.486 [88.54]	±0.017 [0.43]	in [mm]
Ø E	3.374 [85.70]	±0.017 [0.43]	in [mm]
Ø I	3.230 [82.04]	±0.015 [0.38]	in [mm]
OAH	2.520 [64.01]	±0.015 [0.38]	in [mm]
H	0.520 [13.21]	±0.015 [0.38]	in [mm]
Ø OD	3.506 [89.05]	±0.017 [0.43]	in [mm]
PART WEIGHT	32.90	±2.50	g
VOLUME	10.48 [310.0]	REFERENCE	fl oz [cc]
THREAD DETAIL INFORMATION: 5 THREADS PER INCH 0.200" [5.08] PITCH 450° FULL DEPTH THREADS			

DISCLAIMER

THIS INFORMATION IS PROVIDED AS A GENERAL GUIDE, INCLUDING DIMENSIONS. IT IS THE CUSTOMER'S RESPONSIBILITIES TO SELECT THE PROPER CONTAINER FOR PRODUCT AND APPLICATION COMPATIBILITY.

DISTRIBUTED BY:



REF NO.:

DWG10326

DESCRIPTION:

8 oz PP Straight Sided Jar, 89-400, Regular Wall

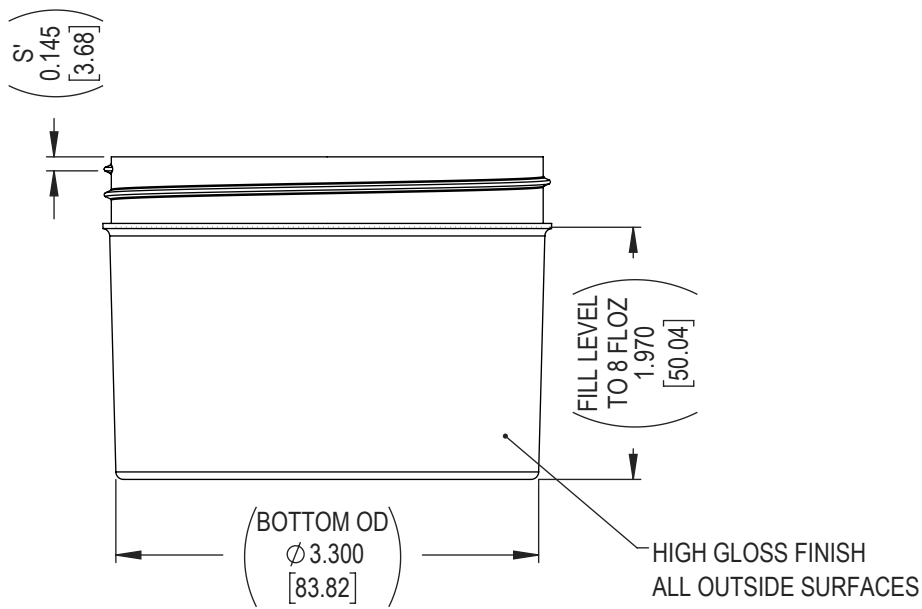
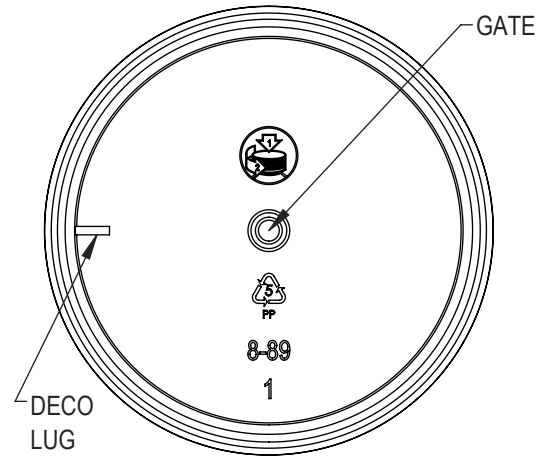
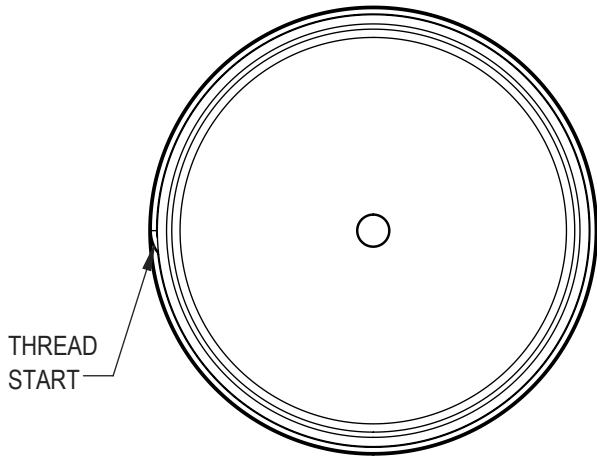

DISCLAIMER

THIS INFORMATION IS PROVIDED AS A GENERAL GUIDE, INCLUDING DIMENSIONS. IT IS THE CUSTOMER'S RESPONSIBILITIES TO SELECT THE PROPER CONTAINER FOR PRODUCT AND APPLICATION COMPATIBILITY.

DISTRIBUTED BY:



REF NO.:

DWG10326

DESCRIPTION:

8 oz PP Straight Sided Jar, 89-400, Regular Wall

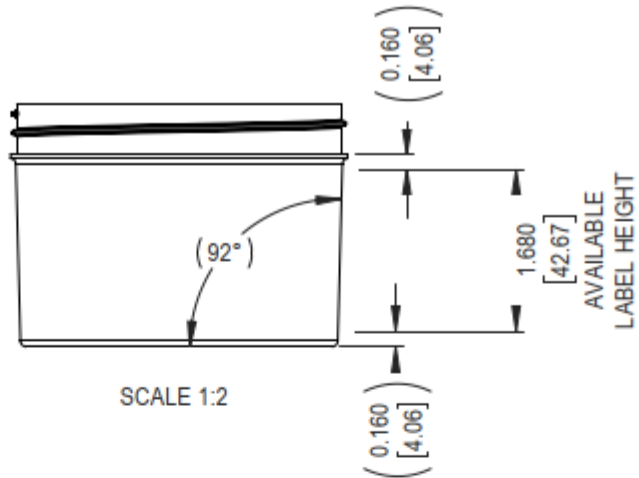

AVAILABLE LABEL AREA

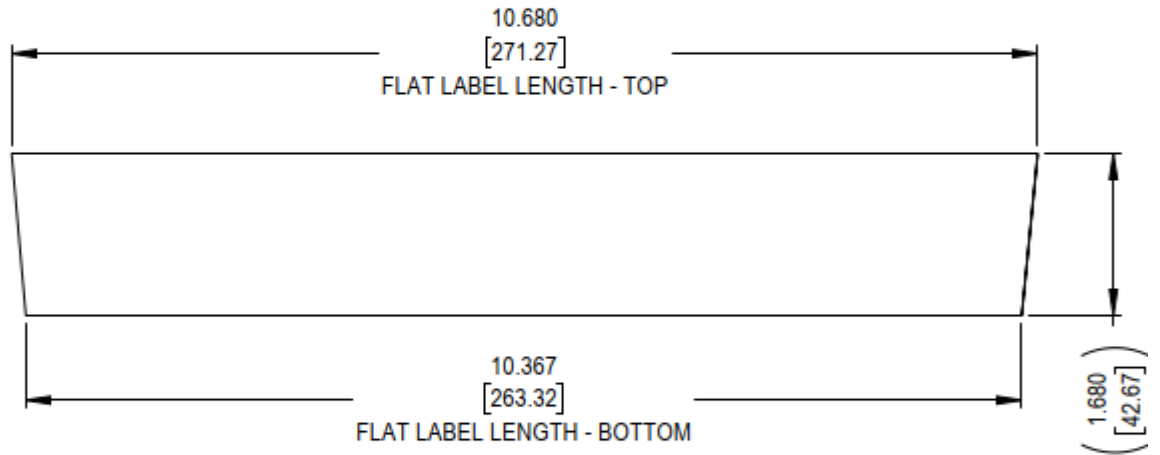

PRINT DIE LINES

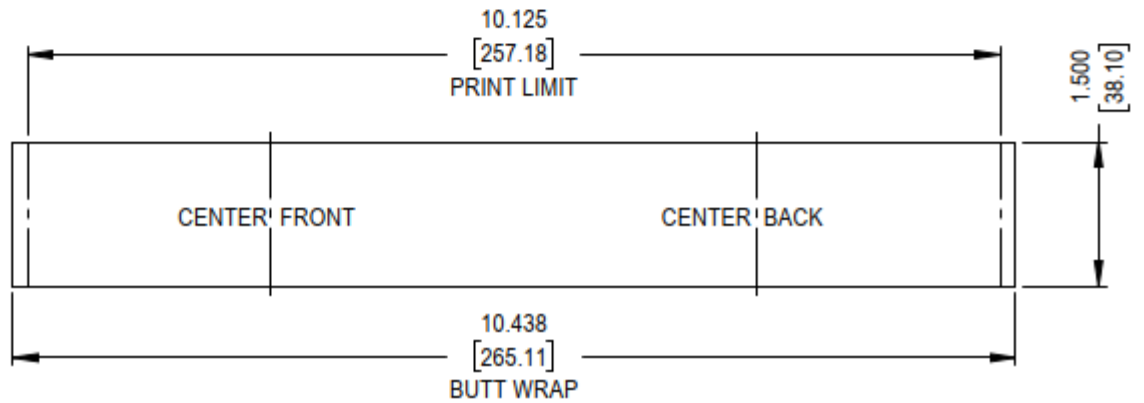

DISTRIBUTED BY:



REF NO.:

DWG10326

DESCRIPTION:

8 oz PP Straight Sided Jar, 89-400, Regular Wall

DISCLAIMER

THIS INFORMATION IS PROVIDED AS A GENERAL GUIDE, INCLUDING DIMENSIONS. IT IS THE CUSTOMER'S RESPONSIBILITIES TO SELECT THE PROPER CONTAINER FOR PRODUCT AND APPLICATION COMPATIBILITY.