

Features

Built in hand grips
Gauge: 65 mil.
Nominal capacity: 4.25 USG / 16.0 L
Stack performance: 175 lbs.*
Tare weights: Body: 1.50 lbs. / .68 kgs.
Cover: .37 lbs. / .17 kgs.

Note: *Ratings will be reduced with uneven load distribution.

Specifications with Cover

Dimensions: 9-15/16" X 9-15/16" X 14-3/4"H
Maximum capacity: 4.4 USG / 16.6 L
Tare weight: 1.87 lbs. / .85 kgs.

Colors

Standard: White, Black and Natural
Custom: Available at manufacturer's discretion

Decorating Options

Silk - Screening 5"W X 8-1/2"H
Four or six* color offset printing
Print area: 5"W X 8-1/2"H on each panel
Sleeve or pressure sensitive labeling

Note: *Where available

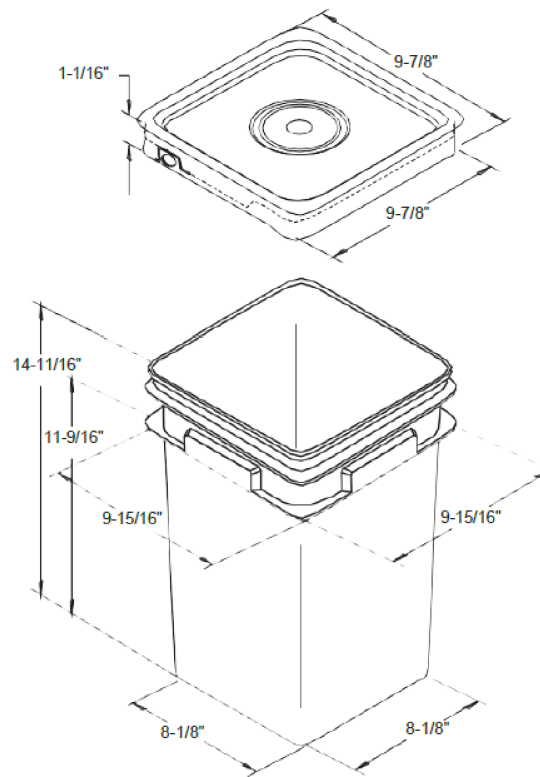

Shipping Data

Qty. per pallet:
Gross Weight (lbs./kgs.)**:
Den. (lbs./C.F./kgs./m3):
Length (in./cm.):
Width (in./cm.):
Height (in./cm.):

Bodies

240
360/163.2
6.0/96.5
51.2/130
42/106.7
48/121.9

Covers

2,304 (24 boxes of 96)*
852.5/391.7
8.0/129.9
51/129.5
41/104.1
89/223.6

Filled Containers

60 (20 per layer / 3 layers high)
Pallet height: 48.7"

Estimated truckload quantity of 11,040 bodies and covers***

Notes: *Bulk pack also available

**Weight does not include pallet/packaging

***Truckload quantity based on 53' trailer

Materials

FDA approved materials
Resin: Body: High-Density Polyethylene (HDPE)
or Clear Polypropylene (PP)
Cover: High-Density Polyethylene (HDPE)
MSDS Sheets available upon request

Optional Carrying Handle

DISCLAIMER THIS INFORMATION IS PROVIDED AS A GENERAL GUIDE, INCLUDING DIMENSIONS. IT IS THE CUSTOMER'S RESPONSIBILITIES TO SELECT THE PROPER CONTAINER FOR PRODUCT AND APPLICATION COMPATIBILITY.	DISTRIBUTED BY:  Pipeline Packaging	REF NO.: DWG10431
	DESCRIPTION: 4.25 Gal HDPE Square Pail	