

Product Specifications

Tamper-Evident Square Hinged EZ Cover® with Ring Pull® (SHLR)

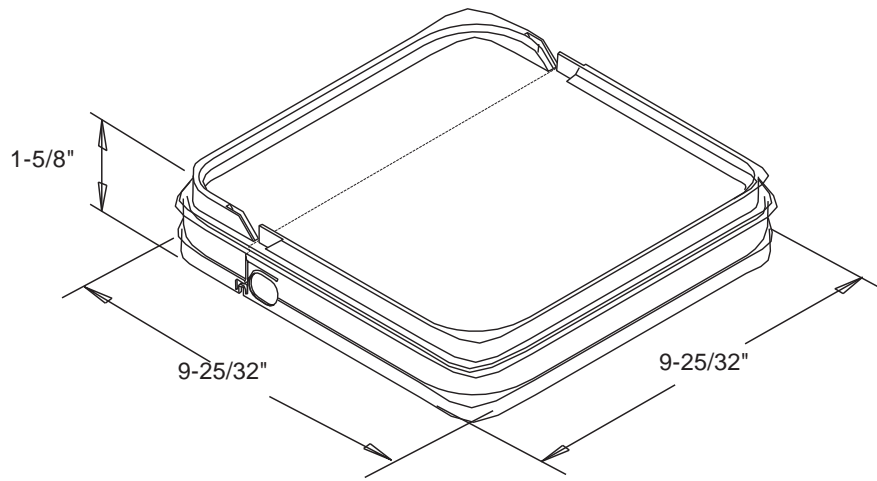

Features

- Exclusive EZ Cover® design with Ring Pull®
- EZ to open and reseal
- Tamper-evident tear strip
- Medium duty cover performance
- Dry seal closure

Used with Ropak Square Bodies

<u>Models</u>	<u>Nominal capacity</u>
SA26	2.1-gallon
S026	2.1-gallon
S337	3.3-gallon
S357	3.5-gallon
S377	3.7-gallon
S047	4-gallon
SA48	4-gallon
S048	4-gallon
S427	4.25-gallon
S438	4.25-gallon
S05C	5-gallon

Product Weight

SHLR: .31 lbs. /.14 kgs.

Shipping Data

Qty. per pallet:	1,800 (24 boxes of 75)
Gross Weight (lbs./kgs.):	558/252
Length (in./cm.):	51.5/130.8
Width (in./cm.):	40/101.6
Height (in./cm.):	92.5/235

Materials

Resin: Polypropylene (PP)

FDA and USDA Approved materials

DISTRIBUTED BY:



REF NO.:

DWG31276

DESCRIPTION:

4.25 Gallon White HDPE Square Cover, with Gasket
Ropak

DISCLAIMER

THIS INFORMATION IS PROVIDED AS A GENERAL GUIDE, INCLUDING DIMENSIONS. IT IS THE CUSTOMER'S RESPONSIBILITIES TO SELECT THE PROPER CONTAINER FOR PRODUCT AND APPLICATION COMPATIBILITY.