

**TOP VIEW**

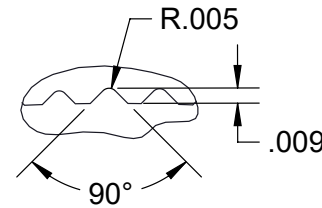

**DECORATION DETAIL**  
(180) EQUISPACED RIBS  
SCALE: 10-1

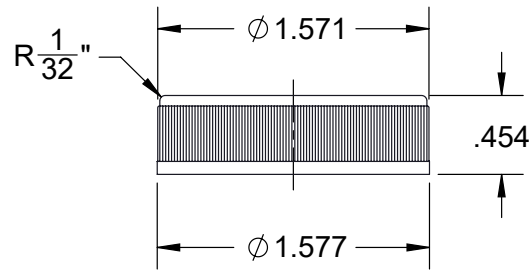
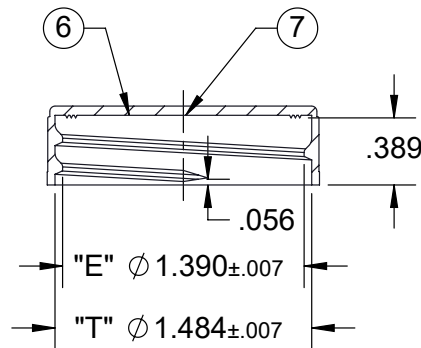

**NOTES:**

1. MATERIAL: POLYPROPYLENE
2. 6 THREADS/INCH
3. ALL FILLETS & RADII TO BE: .010" U.O.S.
4. TOLERANCES TO BE: ±.010" U.O.S.
5. DRAFT TO BE: 1/2° U.O.S.
6. CAVITY NUMBER
7. GATE LOCATION: INSIDE, CENTER
8. PART WEIGHT: 2.7g ± 0.3g

**DISCLAIMER**

THIS INFORMATION IS PROVIDED AS A GENERAL GUIDE, INCLUDING DIMENSIONS. IT IS THE CUSTOMER'S RESPONSIBILITIES TO SELECT THE PROPER CONTAINER FOR PRODUCT AND APPLICATION COMPATIBILITY.

DISTRIBUTED BY:



REF NO.:

DWG30447

DESCRIPTION:

38-400 White PP Smooth Top, Ribbed Sides Cap with F217 Foam Liner

- This data sheet describes F-217® products
- This product is a three-ply co-extruded liner consisting of a foamed Low Density Polyethylene (LDPE) core sandwiched between two layers of solid Low Density Polyethylene

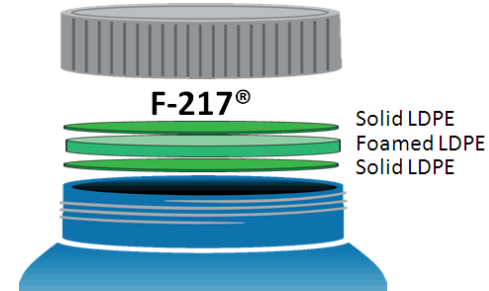

<b>Typical Product Attributes</b>		
<b>Construction</b>		
Structure	Solid LDPE / Foamed LDPE / Solid LDPE	Solid LDPE / Foamed LDPE / Solid LDPE
Color	White or as Specified	White or as Specified
Density		
for 20 ~ 30 mil (0,51 ~ 0,76 mm)	0,48 ± 0,03 g / cm <sup>3</sup>	30 ± 2 lbs / ft <sup>3</sup>
for 35 ~ 125 mil (0,89 ~ 3,18 mm)	0,40 ± 0,03 g / cm <sup>3</sup>	25 ± 2 lbs / ft <sup>3</sup>
Thickness Tolerance		
for 20 ~ 60 mil (0,51 ~ 1,52 mm)	± 0,127 mm	± 5 mil
for 65 ~ 90 mil (1,65 ~ 2,29 mm)	± 0,178 mm	± 7 mil
for 95 ~ 125 mil (2,41 ~ 3,18 mm)	± 0,254 mm	± 10 mil
Available Width		
for 20 ~ 60 mil (0,51 ~ 1,52 mm)	22,2 ~ 1016,0 mm	7/8 ~ 40 inch
for 65 ~ 125 mil (1,65 ~ 3,18 mm)	25,4 ~ 228,6 mm	1 ~ 9 inch
Width tolerance	± 1,6 mm	± 1/16 inch
<b>Regulatory Compliance</b>		
FDA Compliance	21 CFR 177.1520 (Olefin Polymers) 21 CFR 177.1210 (Closures with Sealing Gaskets for Food Containers) 21 CFR 178.2010 (Antioxidants and/or Stabilizers for Polymers) 21 CFR 175.300 (Resinous and Polymeric Coatings)	
Drug Master File (DMF)	2434	
Other Compliances	USFDA Food Allergen Guidelines; California Proposition 65 Labeling Requirements; Limitations of Heavy Metals in Packaging per CONEG & EU 94/62/EC, Article 11	

<p align="center"><b>DISCLAIMER</b></p> <p>THIS INFORMATION IS PROVIDED AS A GENERAL GUIDE, INCLUDING DIMENSIONS. IT IS THE CUSTOMER'S RESPONSIBILITIES TO SELECT THE PROPER CONTAINER FOR PRODUCT AND APPLICATION COMPATIBILITY.</p>	<p>DISTRIBUTED BY: </p>	<p>REF NO.: <b>DWG30447</b></p>
	<p>DESCRIPTION: 38-400 White PP Smooth Top, Ribbed Sides Cap with F217 Foam Liner</p>	