

Ø 1.022 ACROSS TORQUE RAMPS
TYP. (2 PLACES)

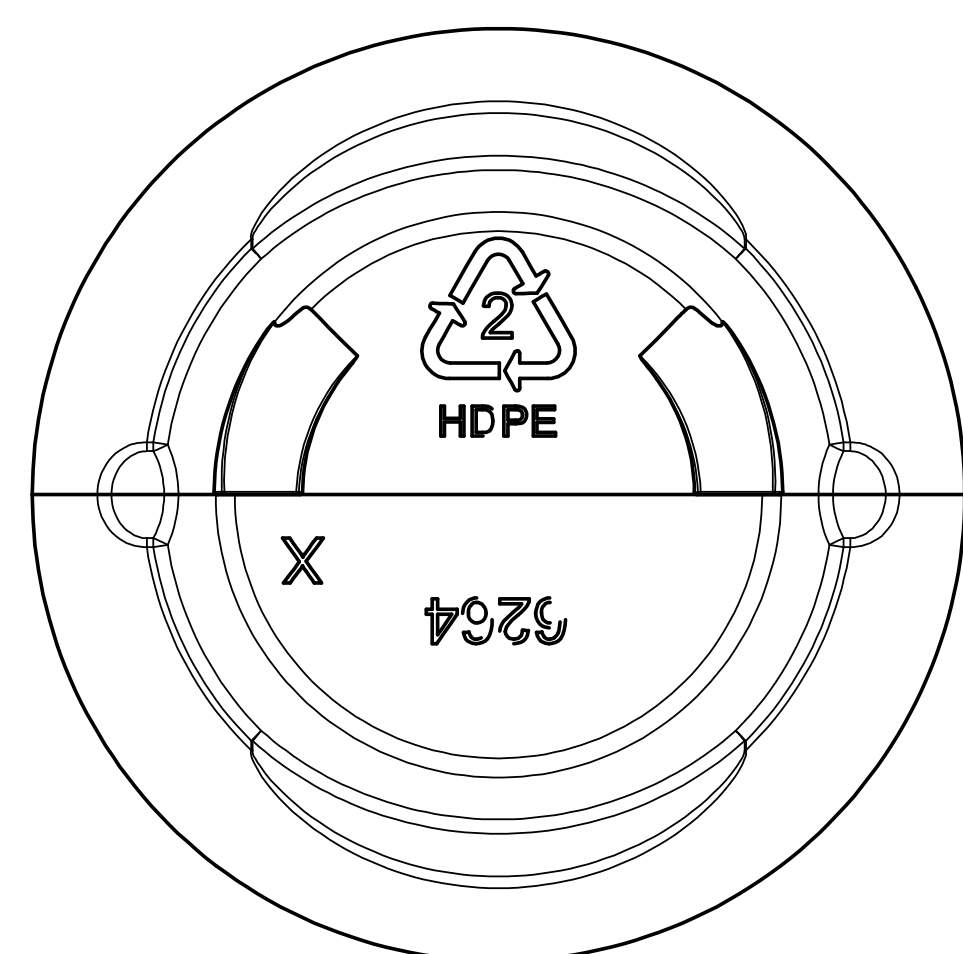
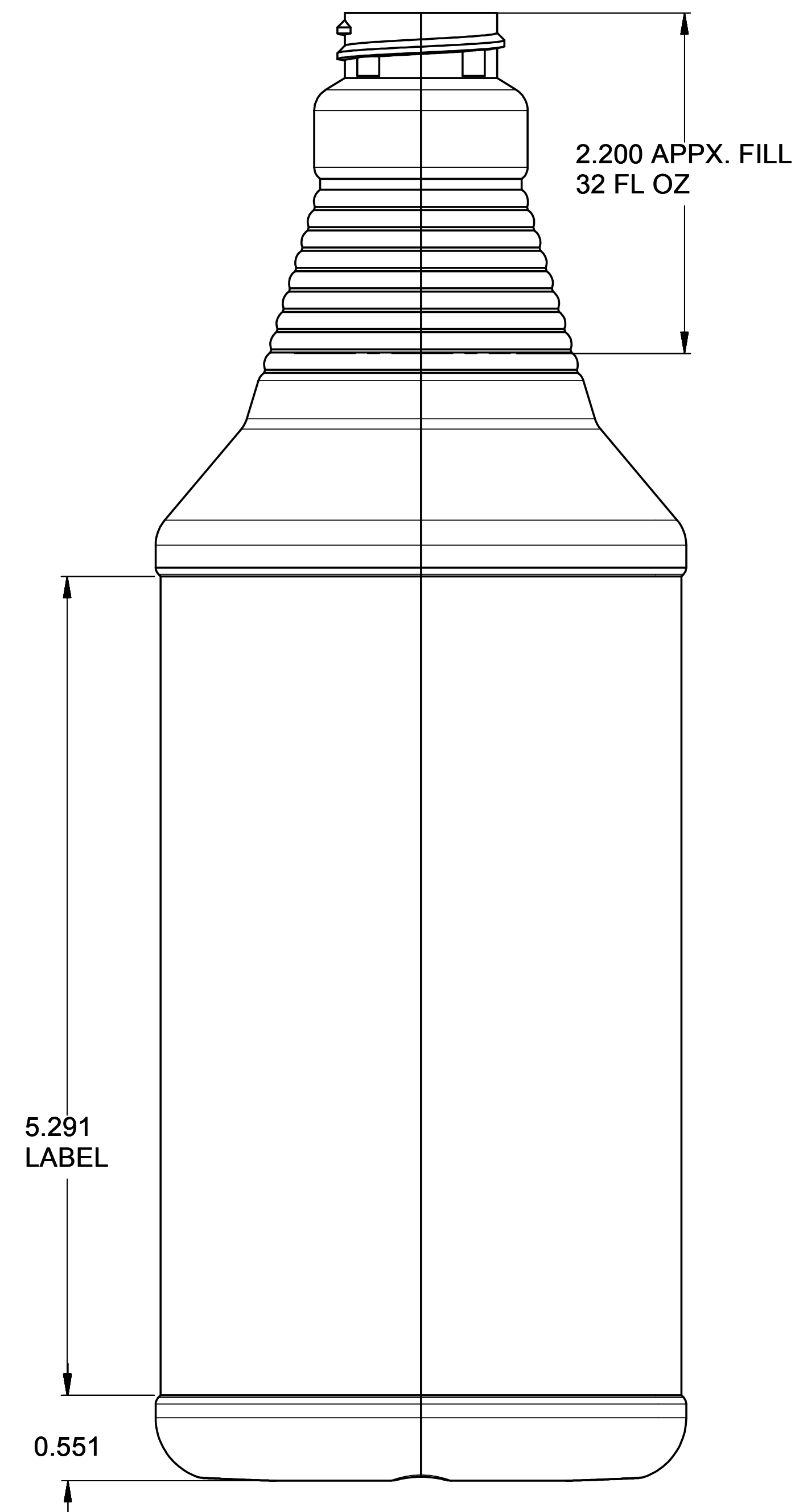
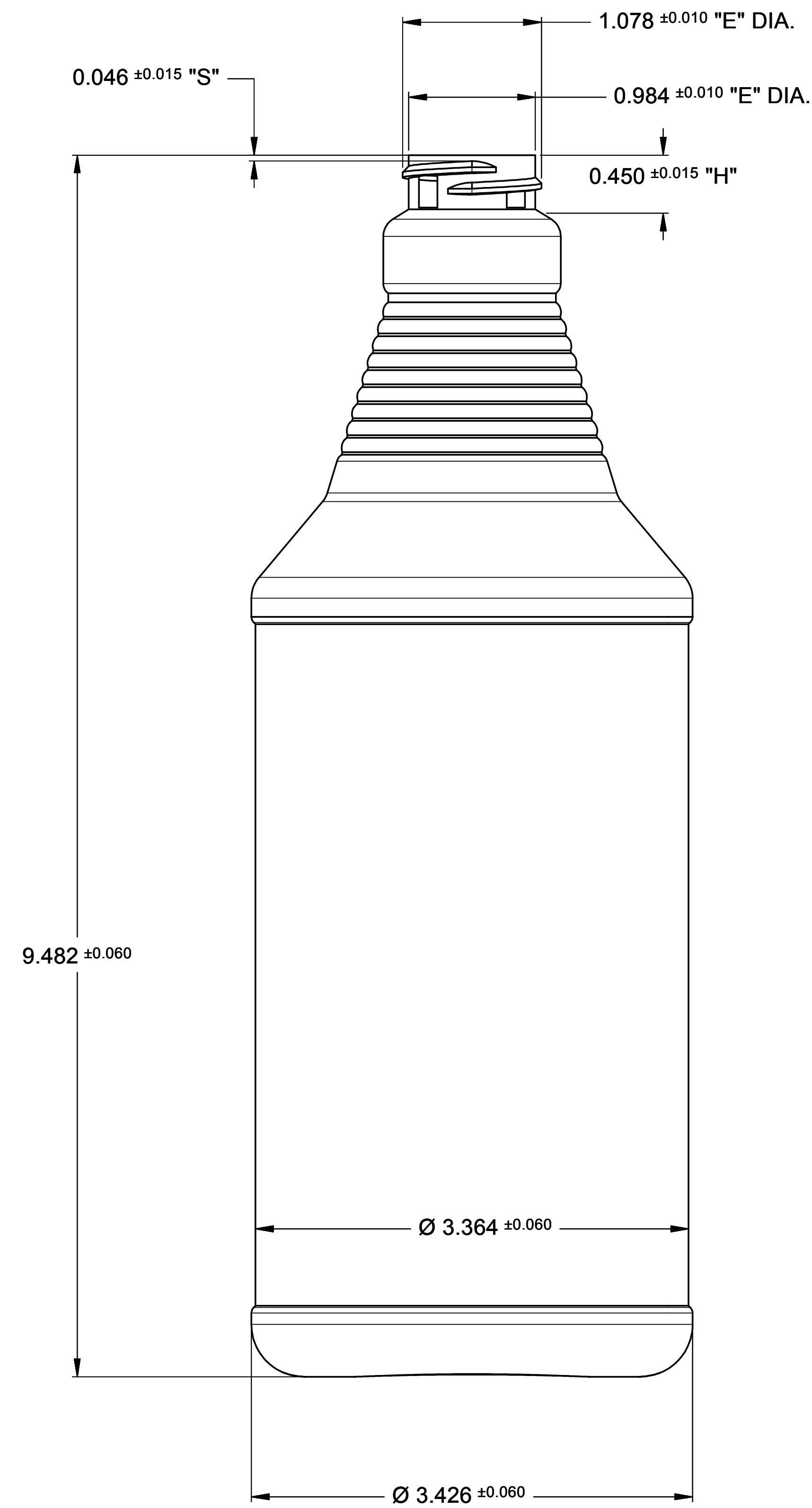

NOTES:

1. SCALE: 1:1
2. FINISH: 28-400 SPECIAL "H" WITH TORQUE RAMPS
3. MATERIAL: HDPE
4. GRAM WT.: 54 GRAMS
5. OVERFLOW CAPACITY: 984 ± 15 CC
6. STANDARD S.P.I. TOLERANCES APPLY TO ALL BODY DIMENSIONS.

DISCLAIMER

THIS INFORMATION IS PROVIDED AS A GENERAL GUIDE, INCLUDING DIMENSIONS. IT IS THE CUSTOMER'S RESPONSIBILITIES TO SELECT THE PROPER CONTAINER FOR PRODUCT AND APPLICATION COMPATIBILITY.

DISTRIBUTED BY:



REF NO.:

DWG31087

DESCRIPTION:

32 oz Natural HDPE Ring Carafe, 28-410, 50 gram