

TOP VIEW

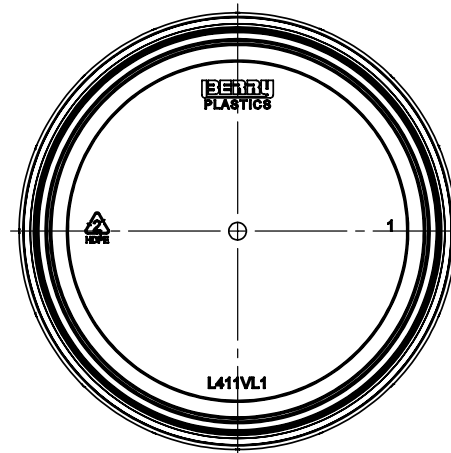

SIDE VIEW



BOTTOM VIEW

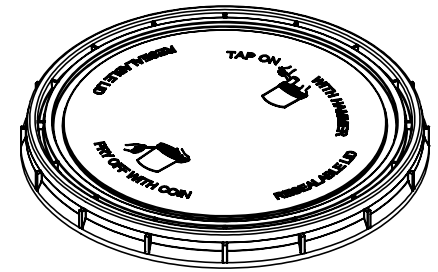

NESTING VIEW

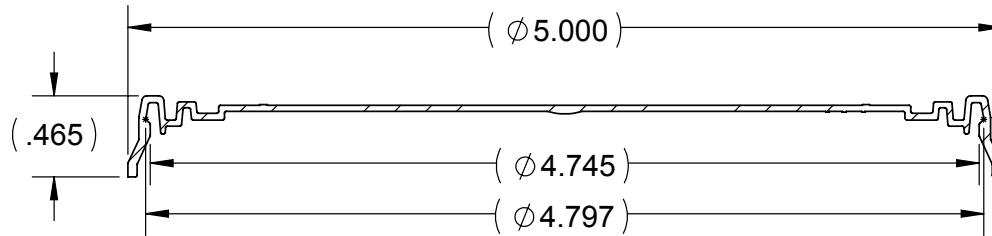

SECTION A-A
SCALE 1 : 1

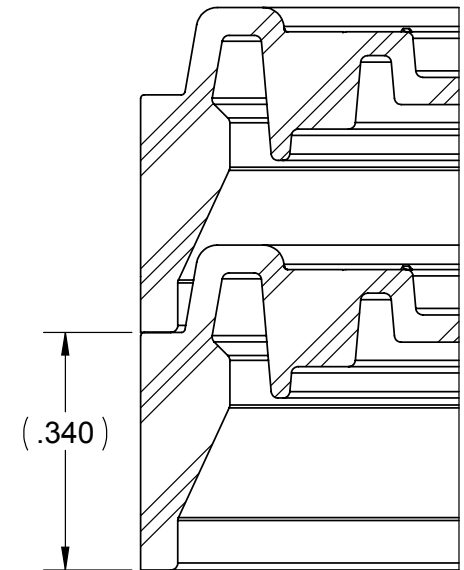

| PART SPECIFICATIONS | |
|-------------------------------|------|
| RESIN FAMILY | HDPE |
| ACTUAL WEIGHT ±X.X (GRAMS) | 18.3 |

DISCLAIMER

THIS INFORMATION IS PROVIDED AS A GENERAL GUIDE, INCLUDING DIMENSIONS. IT IS THE CUSTOMER'S RESPONSIBILITIES TO SELECT THE PROPER CONTAINER FOR PRODUCT AND APPLICATION COMPATIBILITY.

DISTRIBUTED BY:



REF NO.:

DWG31425

DESCRIPTION:

32 oz - 1 Quart HDPE Plastic Vapor Lock Lid