

# Product Specifications

## 3/4 Gallon EZ STOR<sup>®</sup> Container with Gasketless Hinged Cover

### Multiple Uses

Dry Products

### Product Codes

Container: **L073**

Description: 3/4-gallon rectangular can

### Features

Gauge: 30 mil.  
Nominal capacity: .75 USG / 2.8 L  
Stack performance: 60 lbs. dry product  
Tare weights: Body: .19 lbs. / .09 kgs.

### Specifications with Cover

Dimensions: 6-3/4"L x 5-1/2"W x 7-7/32"H  
Maximum capacity: .82 USG / 3.1 L  
Tare weight: .23 lbs. / .11 kgs.

### Colors

Standard: White, Black, Natural and Clear  
Custom: Available at manufacturer's discretion

### Decorating Options\*

Pressure sensitive labeling  
Front: 3.5"W x 4.5"H  
Side: 2.25"W x 4.5"H  
In-Mold labeling (IML)

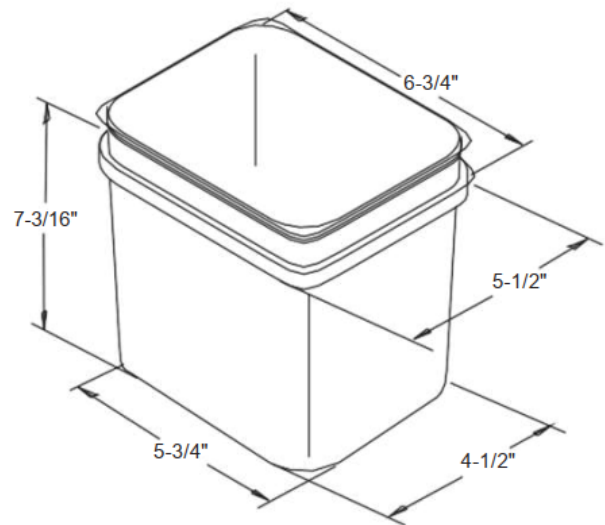

### Shipping Data

Qty. per pallet:	1,813
Gross Weight (lbs./kgs.):*	344.5/163.2
Den. (lbs./C.F./kgs./m3):	6.3/105.8
Length (in./cm.):	48/121.9
Width (in./cm.):	40/101.6
Height (in./cm.):	49/124.5

### Bodies

### Filled Containers

Product designed for use with overpack.

Estimated truckload quantity of 76,146 bodies and 76,500 covers\*\*

Notes: \*Weight does not include pallet / packaging  
\*\*Truckload quantity based on 53' trailer

### Materials

FDA and HPB approved materials  
Resin: Body: Polypropylene (PP)  
or Clarified Polypropylene (for clear)

DISTRIBUTED BY:



REF NO.:

DWG31824

DESCRIPTION:

3/4 Gallon PP Plastic EZ Stor Container

### DISCLAIMER

THIS INFORMATION IS PROVIDED AS A GENERAL GUIDE, INCLUDING DIMENSIONS. IT IS THE CUSTOMER'S RESPONSIBILITY TO SELECT THE PROPER CONTAINER FOR PRODUCT AND APPLICATION COMPATIBILITY.