

SECTION A-A

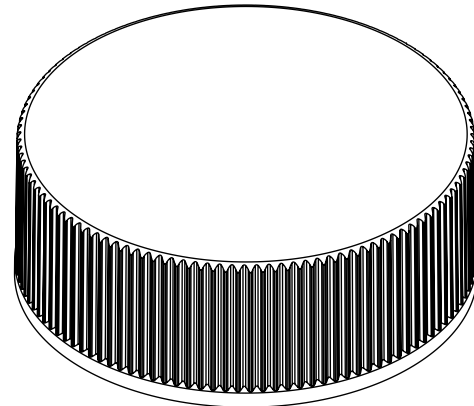

REFERENCE	DIMENSION	TOLERANCE	UNITS
Ø E	1.010 [25.65]	± 0.010 [0.25]	in [mm]
Ø T	1.095 [27.81]	± 0.010 [0.25]	in [mm]
H	0.390 [9.91]	± 0.010 [0.25]	in [mm]
OAH	0.445 [11.30]	± 0.010 [0.25]	in [mm]
OD	1.205 [30.61]	± 0.010 [0.25]	in [mm]
PART WEIGHT	1.93	±0.15	g

DISCLAIMER

THIS INFORMATION IS PROVIDED AS A GENERAL GUIDE, INCLUDING DIMENSIONS. IT IS THE CUSTOMER'S RESPONSIBILITIES TO SELECT THE PROPER CONTAINER FOR PRODUCT AND APPLICATION COMPATIBILITY.

DISTRIBUTED BY:



REF NO.:

DWG31199

DESCRIPTION:

28-400 White PP Smooth Top, Ribbed Sides
Cap with F217 & PS22 Printed Liner

- This data sheet describes F-217® products
- This product is a three-ply co-extruded liner consisting of a foamed Low Density Polyethylene (LDPE) core sandwiched between two layers of solid Low Density Polyethylene

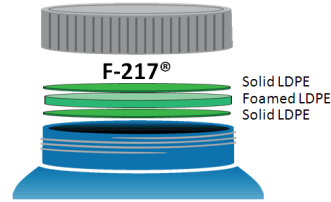

MRP Description - (024)F217.035 PL

Typical Product Attributes

Construction

Structure	Solid LDPE / Foamed LDPE / Solid LDPE	Solid LDPE / Foamed LDPE / Solid LDPE
Color	White or as Specified	White or as Specified
Density		
for 20 ~ 30 mil (0,51 ~ 0,76 mm)	0,48 ± 0,03 g / cm ³	30 ± 2 lbs / ft ³
for 35 ~ 125 mil (0,89 ~ 3,18 mm)	0,40 ± 0,03 g / cm ³	25 ± 2 lbs / ft ³
Thickness Tolerance		
for 20 ~ 60 mil (0,51 ~ 1,52 mm)	± 0,127 mm	± 5 mil
for 65 ~ 90 mil (1,65 ~ 2,29 mm)	± 0,178 mm	± 7 mil
for 95 ~ 125 mil (2,41 ~ 3,18 mm)	± 0,254 mm	± 10 mil
Available Width		
for 20 ~ 60 mil (0,51 ~ 1,52 mm)	22,2 ~ 1016,0 mm	7/8 ~ 40 inch
for 65 ~ 125 mil (1,65 ~ 3,18 mm)	25,4 ~ 228,6 mm	1 ~ 9 inch
Width tolerance	± 1,6 mm	± 1/16 inch

Regulatory Compliance

FDA Compliance	21 CFR 177.1520 (Olefin Polymers) 21 CFR 177.1210 (Closures with Sealing Gaskets for Food Containers) 21 CFR 175.300 (Resinous and Polymeric Coatings)
Drug Master File (DMF)	2434
Other Compliances	USFDA Food Allergen Guidelines; California Proposition 65 Labeling Requirements; Limitations of Heavy Metals in Packaging per CONEG & EU 94/62/EC, Article 11

PressureSeal 20

- PressureSeal 20 is an inner seal with a construction of polystyrene foam coated with pressure sensitive adhesive.
- The US FDA does not consider liners applied with pressure sensitive adhesive to be an effective tamper-resistant feature.
- Recommended for use with dry products.
- Available with standard or custom print.

Typical Product Attributes

Construction

		SI (µm)	US (Mils)
Polystyrene Foam		508,0	20.0
Pressure Sensitive Adhesive		50,8 ~ 76,2	2.0 ~ 3.0
Thickness Tolerance		± 10%	± 10%
Minimum Width		25,4 mm	1.0 in
Width Tolerance		± 1,6 mm	± 0.0625 in

Properties

Oxygen Transmission (O ₂ TR)	Not Tested
Water Vapor Transmission (WVTR)	Not Tested

Regulatory Compliance

FDA Compliance	21 CFR 177.1640 Polystyrene and rubber-modified polystyrene. 21 CFR 177.1210 Closures with sealing gaskets for food containers. 21 CFR 175.125 Pressure-sensitive adhesives.
Drug Master File (DMF)	002518
Other Compliances	USFDA Food Allergen Guidelines California Proposition 65 Labeling Requirements Limitations of Heavy Metals in Packaging per CONEG & EU 94/62/EC, Article 11
Safety Data Sheet (SDS) Statement	Safety Data Sheets (SDS) are not required for articles as defined in 29 CFR 1910.1200, the OSHA Hazard Communication Standard (HazCom). This product is an article as defined by HazCom and is not considered to be, or to contain, a hazardous chemical based on evaluations made by our company.

Please note that construction does not reflect adhesive or resin bonding layers, if present.

Page 2 of 2

DISTRIBUTED BY:



REF NO.:

DWG31199

DISCLAIMER
THIS INFORMATION IS PROVIDED AS A GENERAL GUIDE, INCLUDING DIMENSIONS. IT IS THE CUSTOMER'S RESPONSIBILITIES TO SELECT THE PROPER CONTAINER FOR PRODUCT AND APPLICATION COMPATIBILITY.

DESCRIPTION:

28-400 White PP Smooth Top, Ribbed Sides
Cap with F217 & PS22 Printed Liner