

ITEM	MINIMUM	TARGET	MAXIMUM
WEIGHT (grams)	358	363	368
T	2.487	2.505	2.523
A		N/A	
E	2.339	2.357	2.375
I	2.112	2.130	2.148
S	.060	.075	.090
H - SEE REFERENCE	.704	.719	.734
SLANT			.020
OVALITY			.050
WALL THICKNESS	.050		
BUMPER THICKNESS	.030		
BUMPER CORNERS	.030		
WALL VARIATION	.012		
CORNERS BY HANDLE	.020		

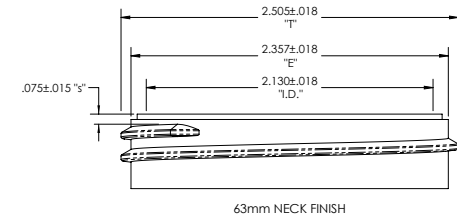
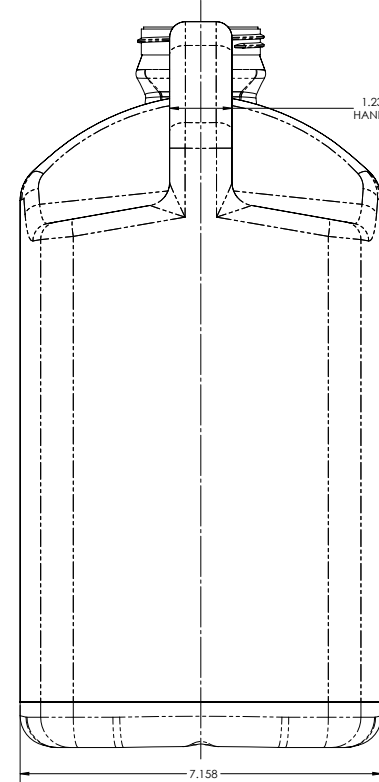
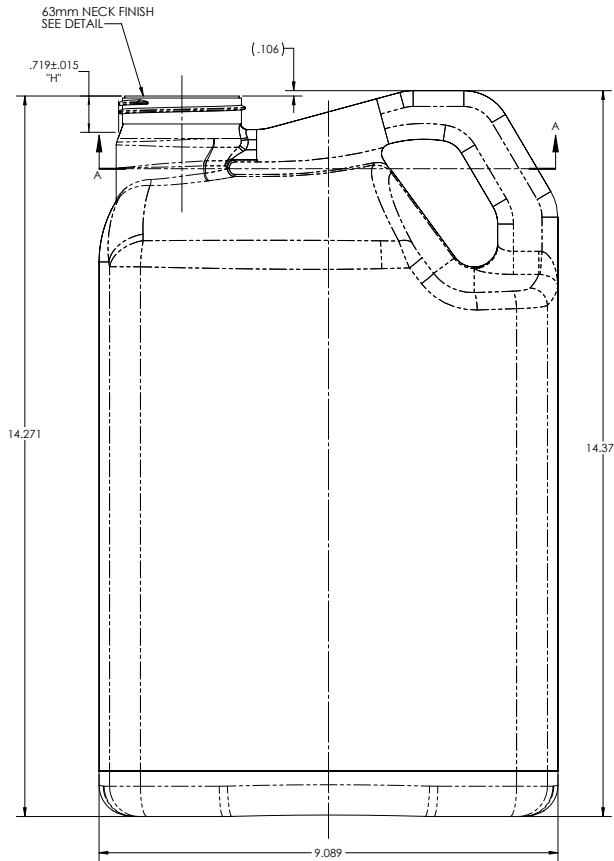
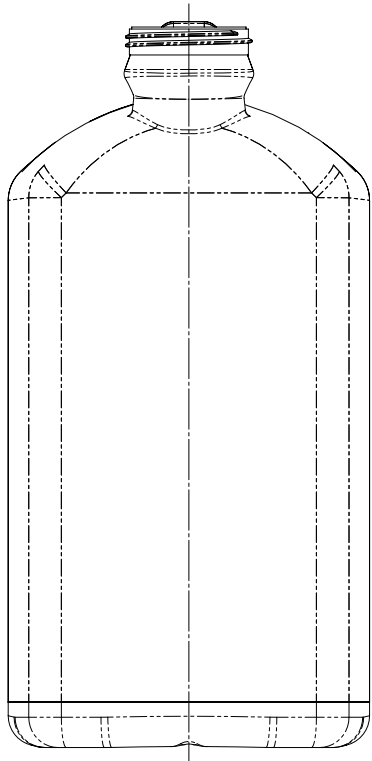

DISCLAIMER

THIS INFORMATION IS PROVIDED AS A GENERAL GUIDE, INCLUDING DIMENSIONS. IT IS THE CUSTOMER'S RESPONSIBILITIES TO SELECT THE PROPER CONTAINER FOR PRODUCT AND APPLICATION COMPATIBILITY.

DISTRIBUTED BY:



REF NO.:

DWG30290

DESCRIPTION:

2.5 Gallon HDPE F-Style, 63-485, No Glug, Kraft Reshipper Box 2x1