

2 Gallon Round Container

Features

- Reinforcing ribs to maintain container shape
- Tapered design allows for container nesting
- Heat transfer decoration and 6 color offset print capability
- Accepts plastic or metal handle

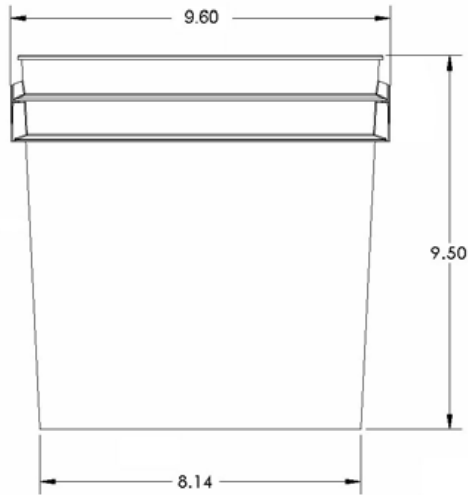

PRODUCT CODE.....2D (TJ2G70)

COMPATIBLE LIDS..... 2LTT (LI2GGTS) & 2LH (LI2GGCT)

SPECIFICATIONS

Height.....9.50"
 Outer Diameter.....9.60"
 Thickness.....70 mil
 Print Area.....25.25" x 5.25"
 Resin.....HDPE

VOLUME

Practical Fill.....2.20 gal. / 8.33 liters
 Overflow.....2.38 gal. / 9.01 liters

PACKAGING

Pack Count.....360
 Pack Dimensions.....51.3" x 40.8" x 46.9"
 Cubic Feet..... 56.8
 Packs per Pallet.....2

ORDER QUANTITIES (53' Truckload)

2D with compatible lids..... 14,400 bases & lids

DISCLAIMER

THIS INFORMATION IS PROVIDED AS A GENERAL GUIDE, INCLUDING DIMENSIONS. IT IS THE CUSTOMER'S RESPONSIBILITIES TO SELECT THE PROPER CONTAINER FOR PRODUCT AND APPLICATION COMPATIBILITY.

DISTRIBUTED BY:



REF NO.:

DWG31400

DESCRIPTION:

2 Gallon HDPE Plastic OH Pail, with Metal Handle & Plastic Grip, 70 Mil