

NOTES:

- 1) CAPS ARE PRODUCED ACCORDING TO CMA STANDARDS AND ARE SUITABLE FOR GLASS FINISH GPI 110-400
- 2) DIMENSION OF THREAD INTERNAL DIAMETER TAKEN WITH A PLUG GAGE
- 3) MIN. PLASTISOL THICKNESS 0.025" IF APPLICABLE

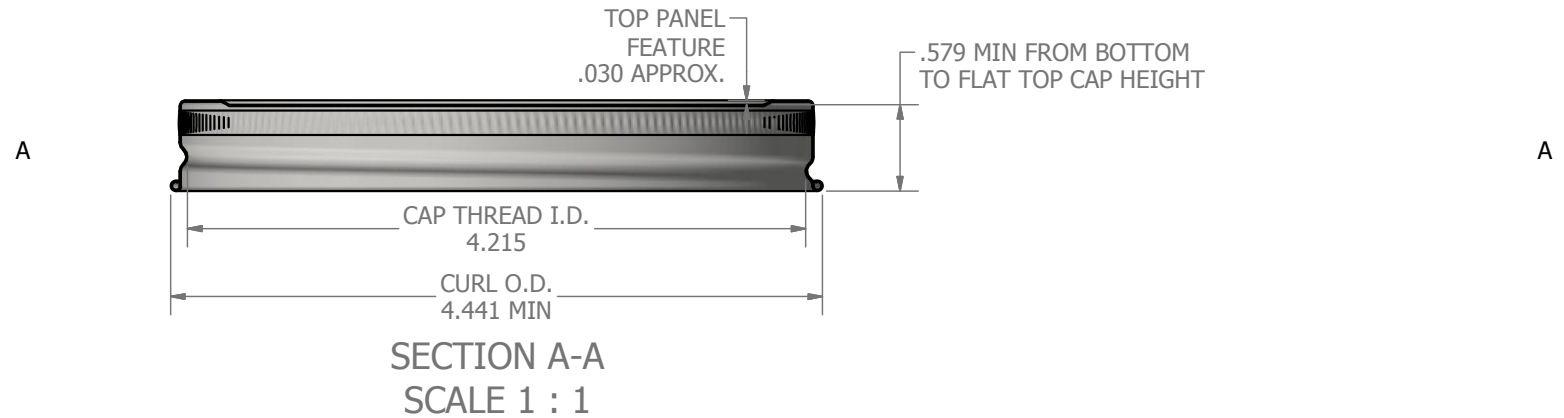

<p><b>DISCLAIMER</b></p> <p>THIS INFORMATION IS PROVIDED AS A GENERAL GUIDE, INCLUDING DIMENSIONS. IT IS THE CUSTOMER'S RESPONSIBILITIES TO SELECT THE PROPER CONTAINER FOR PRODUCT AND APPLICATION COMPATIBILITY.</p>	<p>DISTRIBUTED BY:</p>	<p>REF NO.:</p> <p><b>DWG30985</b></p>
<p>DESCRIPTION:</p> <p>110-400 White Metal Cap with Plastisol Liner, No Button</p>		