

10.0 Liter Standalone Tight Head

Product Uses

Liquid Products

Product Codes

Container: Standalone Tighthead

Features

UN Rating: 3H1/Y1.8/100
 Nominal capacity: 2.64 USG / 10.0L
 Maximum capacity: 2.8 USG / 10.6 L
 Tare weights: 1.58 lbs / .72 kgs

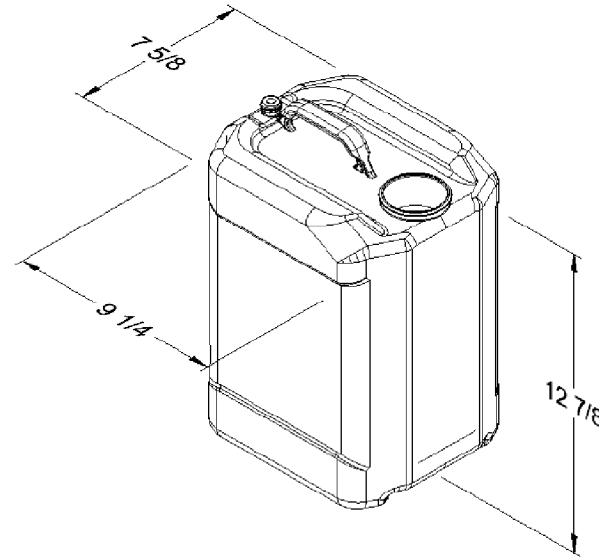

Colors

Standard: White, Black, Blue and Natural
 Custom: Available at manufacturer's discretion

Decorating Options

See Salesperson for Options

Shipping Data

Qty. per floor spot: 200
 Gross Weight (lbs./kgs)*: 285 / 129
 Length (in./cm.): 45.75 / 116
 Width (in./cm.): 38.125 / 97
 Height (in./cm.): 107 / 272

Containers

Filled Containers

Refer to BWAY document # ETS-CD-1002 for storage and shipping recommendations.

Estimated truckload quantity of 6,000 containers**

Notes: *Weight does not include pallet / packaging
 **Truckload quantity based on 53' trailer

Materials

FDA approved materials
 Resin: Body: High-Density Polyethylene (HDPE)

Optional Carrying Handle

Integral

MSDS Sheets available upon request

DISCLAIMER

THIS INFORMATION IS PROVIDED AS A GENERAL GUIDE, INCLUDING DIMENSIONS. IT IS THE CUSTOMER'S RESPONSIBILITIES TO SELECT THE PROPER CONTAINER FOR PRODUCT AND APPLICATION COMPATIBILITY.

DISTRIBUTED BY:



REF NO.:

DWG10195

DESCRIPTION:

10 LITER_HDPE_SQUARE TH PAIL_3H1/Y1.8/100_70MM SCREW CAP, TE