

1.5-Gallon Round Container with Snap-on Cover

Multiple Uses

Dairy Products
Frozen Desserts

Product Codes

Container: **D064**
Description: 1.5 gallon / 6 quart round can

Cover: **D1D0**
Description: Round snap-on cover

Features

Gauge: 40 mil.
Nominal capacity: 1.5 USG / 5.6L
Stack performance: N/A
Tare weights: Body: .31 lbs. / .14 kgs.
Cover: .15 lbs. / .07 kgs.

Specifications with Cover

Dimensions: 9-3/4"D X 6-1/4"H
Maximum capacity: 1.5 USG / 5.6L
Tare weight: .46 lbs. / .21 kgs.

Colors

Standard: White and Natural
Custom: Available at manufacturer's discretion

Decorating Options

Four or six* color offset printing
Print area: 28-1/4"W X 3-1/8"H
Cover: 6-7/8" Diameter

Note: *Where available

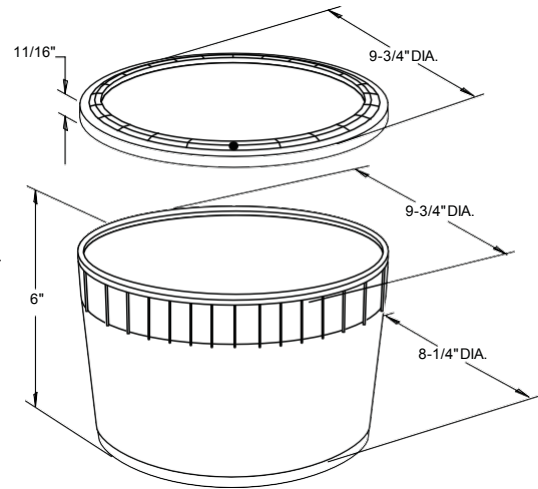

Shipping Data

	Bodies	Covers
Qty. per pallet:	500	3,200 (16 boxes of 200)
Gross Weight (lbs./kgs.):*	155/70	480/224
Den. (lbs./c.f./kgs./m3):	2.8/44.1	4.6/75.2
Length (in./cm.):	49.7/126.2	51/129.5
Width (in./cm.):	40/101.6	41/104.1
Height (in./cm.):	48.7/123.7	87/220.9

Filled Containers

160 (20 per layer/8 layers high)
Pallet height: 53"

Estimated truckload quantity of 21,000 bodies and covers.**

Notes: *Weight does not include pallet/packaging
**Truckload quantity based on 53' trailer

Materials

FDA approved materials
Resin: Body: High-Density Polyethylene (HDPE)
Cover: Linear Low Density Polyethylene (LLDPE)
MSDS Sheets available upon request

DISTRIBUTED BY:



REF NO.:

DWG31279

DESCRIPTION:

1.5 Gallon White HDPE Dairy Tub, Ropak

DISCLAIMER

THIS INFORMATION IS PROVIDED AS A GENERAL GUIDE, INCLUDING DIMENSIONS. IT IS THE CUSTOMER'S RESPONSIBILITIES TO SELECT THE PROPER CONTAINER FOR PRODUCT AND APPLICATION COMPATIBILITY.